

ENGINE

F8QT SERIES

CONTENTS

GENERAL INFORMATION	11A-0-3
1. SPECIFICATIONS	11A-1-1
SERVICE SPECIFICATIONS	11A-1-1
TORQUE SPECIFICATIONS	11A-1-5
FORM-IN-PLACE GASKET	11A-1-8
2. SPECIAL TOOLS	11A-2-1
3. CRANKSHAFT PULLEY	11A-3-1
4. TIMING BELT	11A-4-1
5. WATER PUMP	11A-5-1
6. THERMOSTAT	11A-6-1
7. WATER HOSES AND PIPES	11A-7-1
8. ENGINE COOLANT TEMPERATURE SENSOR	11A-8-1
9. GLOW PLUGS	11A-9-1
10. TURBOCHARGER	11A-10-1
11. INTAKE AND EXHAUST MANIFOLDS	11A-11-1
12. ROCKER COVER AND CYLINDER HEAD	11A-12-1
13. CAMSHAFT, INTAKE AND EXHAUST VALVES	11A-13-1
14. VACUUM PUMP	11A-14-1
15. OIL COOLER AND OIL FILTER	11A-15-1
16. OIL PAN, OIL PUMP AND OIL JETS	11A-16-1
17. INTERMEDIATE SHAFT AND INTERMEDIATE SHAFT BEARINGS	11A-17-1
18. FUEL INJECTION NOZZLE	11A-18-1
19. FUEL INJECTION PUMP	11A-19-1
20. PISTONS AND CONNECTING RODS	11A-20-1
21. PISTONS AND PISTON PINS	11A-21-1
22. FLYWHEEL	11A-22-1
23. CRANKSHAFT AND CYLINDER BLOCK	11A-23-1

NOTES

GENERAL INFORMATION

SECTIONAL VIEW OF ENGINE

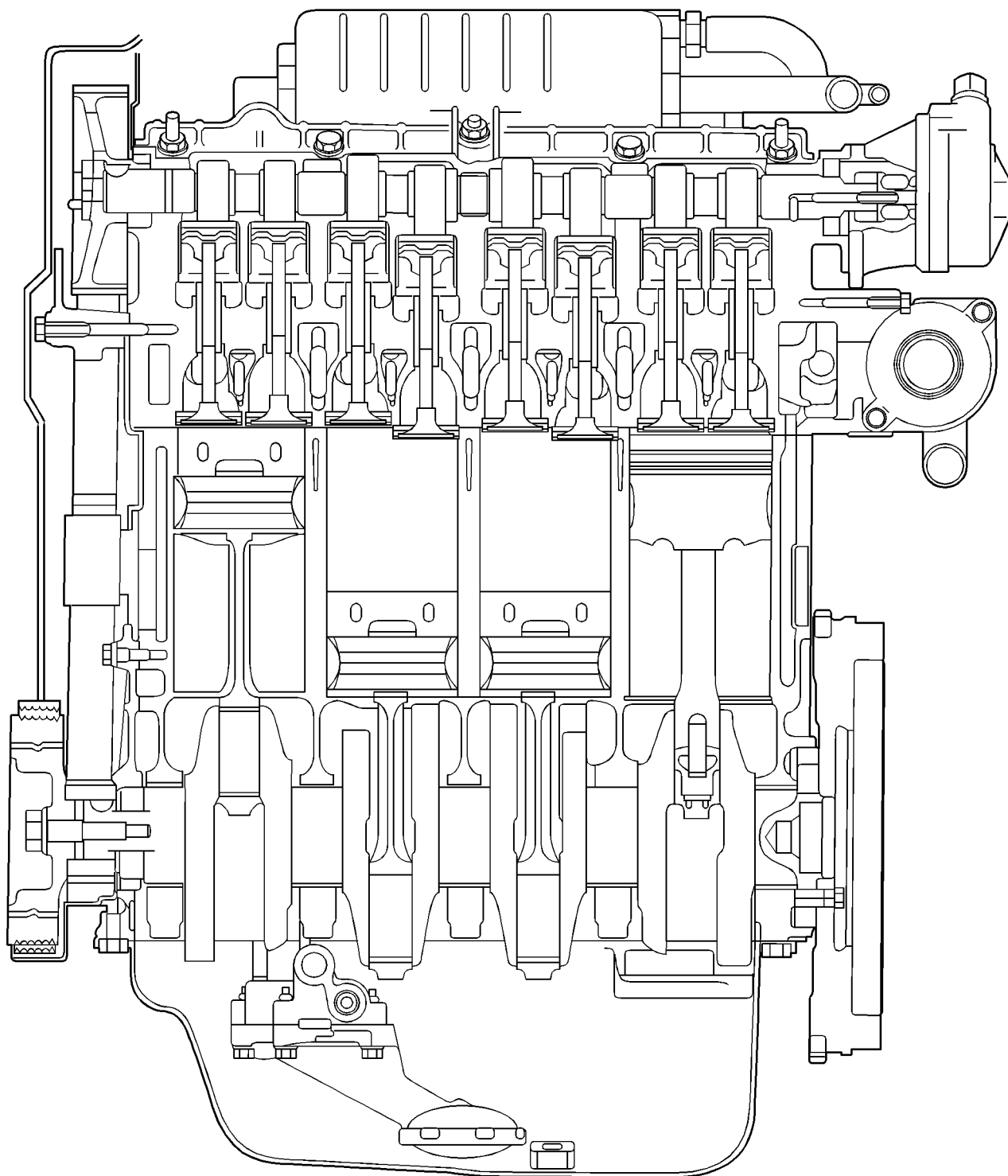

REN0137

SECTIONAL VIEW OF ENGINE

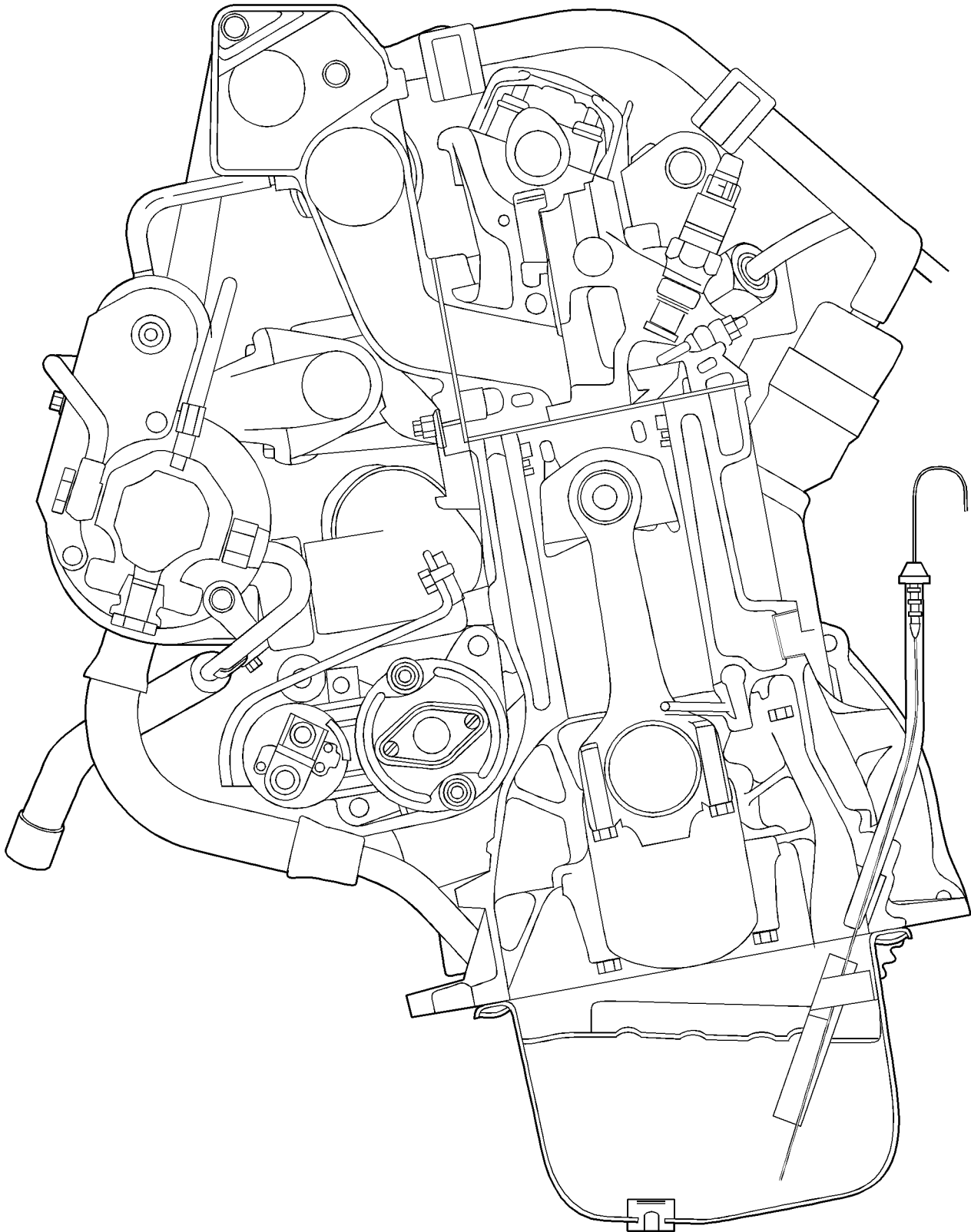

REN0138

SECTIONAL VIEW OF ENGINE

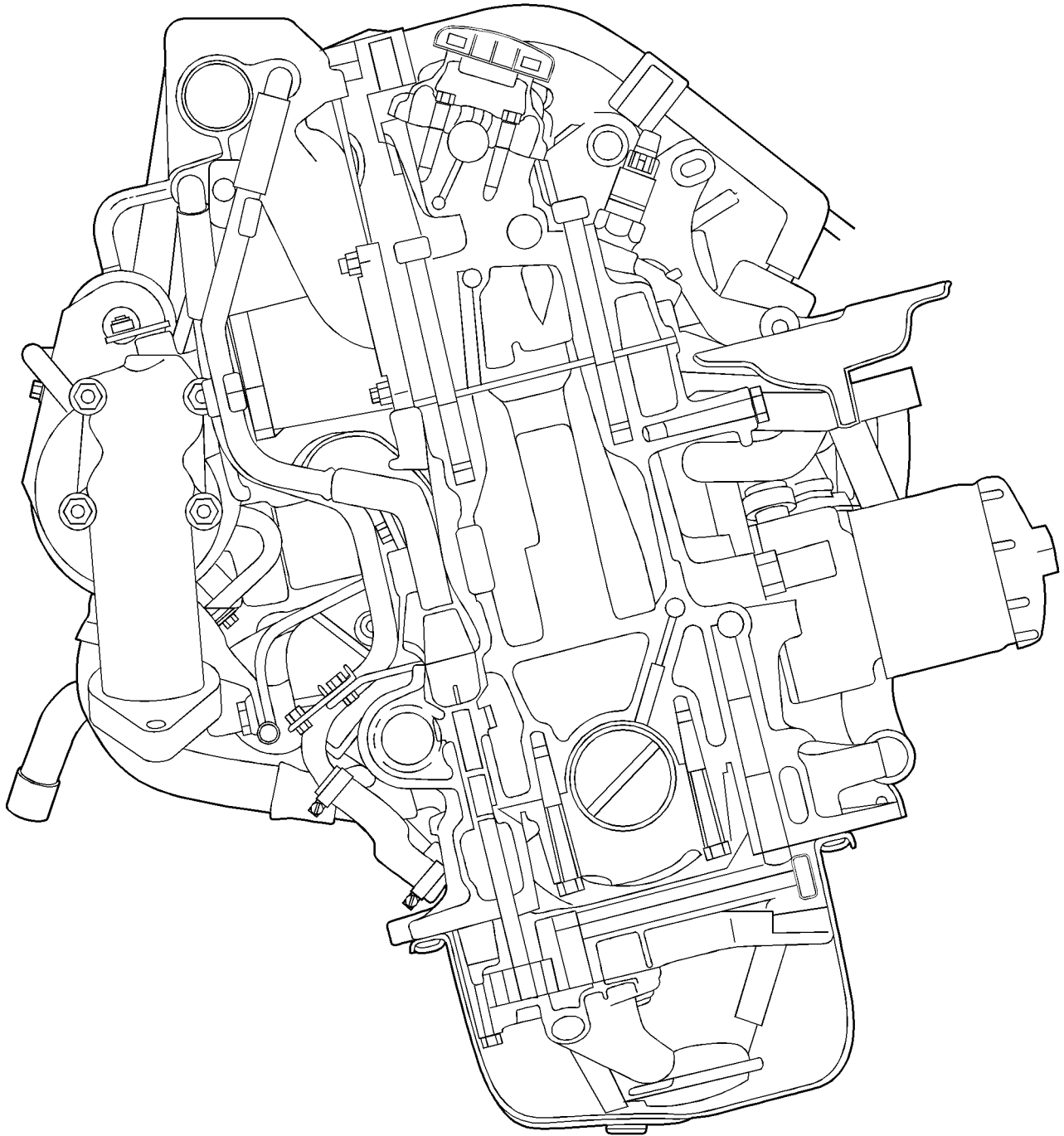

REN0139

Description		Specifications
Type		F8QT diesel engine
Number and arrangement of cylinders		4 in-line
Combustion chamber		Swirl chamber
Total displacement		1870 cm ³
Cylinder bore × stroke		80 × 93 mm
Compression ratio		21
Valve mechanism		Single overhead camshaft
Number of valves	Intake	4
	Exhaust	4
Valve timing	Intake opening	0° BTDC
	Intake closing	18° ABDC
	Exhaust opening	41° BBDC
	Exhaust closing	0° ATDC
Turbocharger		Exhaust gas turbocharger
Intercooler (charge cooling)		Air-cooled
Fuel injection pump		Electric with immobilizer

1. SPECIFICATIONS

SERVICE SPECIFICATIONS

Item		Standard	Limit	
Cylinder head				
Flatness of cylinder head surface mm		0.05	-	
Cylinder head gasket				
Gasket thickness mm	Projecting height of piston - 0.073	Number of holes; 2	1.4	-
	Projecting height of piston 0.073 - 0.206	Number of holes; 1	1.5	-
	Projecting height of piston 0.206 -	Number of holes; 3	1.6	-
Cylinder block				
Cylinder diameter mm	Class A	80.006 - 80.024	-	
	Class B	80.256 - 80.274	-	
Pistons				
Piston-to-cylinder clearance mm		0.021 - 0.055	-	
Standard, class A		79.971 - 79.985	-	
Standard, class B		80.221 - 80.235	-	
Piston rings				
Height mm	Top	2.5	-	
	Bottom	2	-	
	Oil	3	-	
Axial clearance in piston groove mm	Top	0.030 - 0.065	-	
	Bottom	0.030 - 0.065	-	
	Oil	0.030 - 0.065	-	
Fitted gap (in cylinder) mm	Top	0.30 - 0.40	-	
	Bottom	0.25 - 0.40	-	
	Oil	0.25 - 0.50	-	
Piston pin				
Diameter mm		26	-	

Item		Standard	Limit	
Camshaft				
Cam height	Intake	8.5	-	
	Exhaust	10.34	-	
Camshaft end play mm		0.048 - 0.133	-	
Radial clearance mm		0.050 - 0.150	-	
Valves				
Valves clearance mm	Checking	Intake	0.15 - 0.25	-
		Exhaust	0.35 - 0.45	-
	Adjusting	Intake	0.2	-
		Exhaust	0.4	-
Valve diameter mm	Intake	36.22	-	
	Exhaust	31.62	-	
Valve seat angle	Intake	60°	-	
	Exhaust	45°	-	
Valve seat width mm	Intake	1.8 ± 0.2	-	
	Exhaust	1.8	-	
Valve springs				
Length mm	Loading 0 N	43.9	-	
	Loading 250 N	36.8	-	
	Loading 612 N	26.4	-	
Tappets				
Diameter (tolerance) mm		35	-	
Height mm		26.3	-	
Clearance in cylinder block mm		0.025 - 0.075	-	
Valve guides				
Inside diameter mm		8	-	
Outside diameter mm	Standard (no grooves)	13	-	
	Oversize 1 (two grooves)	13.3	-	
Tappet pads				
Thickness (increasing by increments of 0.05) mm		2.50 - 3.70	-	

Item	Standard	Limit
Intermediate shaft		
Inner bearing mm	39.5	-
Outer bearing mm	40.5	-
End play mm	0.07 - 0.15	-
Crankshaft		
End play mm	0.07 - 0.23	-
Thrust washer thickness mm	2.30 - 2.50	-
Radial clearance (main bearings) mm	0.04 - 0.07	-
Main bearing journals		
Ovality mm	-	0.0025
Taper mm	-	0.005
Diameter mm	Standard (blue)	54.785 - 54.805
	Standard (red)	54.795 - 54.805
	Undersize 1	54.550 - 54.560
Big-end bearing journals		
Ovality mm	-	0.0025
Taper mm	-	0.005
Diameter mm	Standard	48.00 - 48.02
	Undersize 1	47.75 - 47.77
Bearing recess width mm	20.25 - 20.95	-
Relative difference mm	-	0.02
Connecting rod (big-end) bearings		
Axial clearance mm	0.22 - 0.40	-
Radial clearance mm	0.031 - 0.075	-
Connecting rods		
Length mm	144 ± 0.02	-
Small end inside diameter mm	26.013 - 26.025	-
Squareness, top/bottom mm	-	0.04
Straightness mm	-	0.1

Item	Standard	Limit	
Flywheel			
Axial throw measured at a radius of 80 mm mm	-	0.07	
Oil pump			
End play mm	0.02 - 0.08	-	
Clearance, gears to pump body (backlash) mm	0.10 - 0.24	-	
Bearing clearance, drive shaft mm	0.024 - 0.49	-	
Number of teeth on oil pump sprocket	8	-	
Oil pressure regulator spring			
Length mm	Loading 0 N	74.6	-
	Loading 10.2 N	48.2	-
	Loading 70 N	41.2	-
Lubrication system			
Oil capacity, exclusive of oil filter L	4.8	-	
Oil capacity, inclusive of oil filter L	5.3	-	
Difference between MAX-MIN marks on dipstick L	1.7	-	
Oil pressure with new filter and hot engine (min.) kPa	- 13 r/s (1,000 rpm)	-	200
	- 50 r/s (3,000 rpm)	-	350

TORQUE SPECIFICATIONS

Items	Nm
Crankshaft pulley	
Crankshaft pulley bolt	120
Timing belt	
Camshaft sprocket bolt	50
Water pump	
Water pump pulley bolt	20
Water pump bolt	12.5
Thermostat	
Thermostat cover bolt	10
Thermostat housing bolt	10
Bleedscrew	0.6
Glow plugs	
Glow plug	22.5
Glow plug nut	5
Turbocharger	
Turbocharger nut	45
Exhaust downpipe connector nut	45
Oil supply pipe union nut	35
Oil return pipe union nut	25
Coolant supply pipe banjo bolt	25
Coolant supply pipe retaining nut	28.7
Coolant discharge pipe union nut	25
Coolant discharge pipe retaining nut	8
Intake and exhaust manifolds	
EGR valve	19.5
EGR pipe	19.5
Oil pipe union nut	30
Oil pipe retaining nut	8
Manifold nut	25

Items	Nm
Rocker cover and cylinder head	
Rocker cover nut	5
Cylinder head bolt	30 + 50° ± 4° + fully slacken + 25 + 213° ± 2° + (warm up) 120° ± 7°
Camshaft, intake and exhaust valves	
Camshaft bearing cap bolt (M6)	10
Camshaft bearing cap bolt (M8)	20
Glow plug	22.5
Fuel injection nozzle	70
Vacuum pump	
Vacuum pump bolt	22
Vacuum hose union nut	22
Oil cooler and oil filter	
Thermostat housing nut	60
Plug	35
Oil cooler nut	60
Oil pan, oil pump and oil jets	
Oil drain plug	15
Oil pan bolt	13
Oil pump cover bolt	12
Oil pump body bolt	22
Oil jet	20
Intermediate shaft and intermediate shaft bearings	
Intermediate shaft sprocket bolt	50
Intermediate shaft cover bolt	15
Intermediate shaft lockplate bolt	15
Cover bolt	15
Fuel injection nozzle	
Injection pipe union nut	22.5
Nozzle body	70
Retaining nut	70

Items	Nm
Fuel injection pump	
Injection pipe union nut	22.5
Screwed sleeve/nut assembly	90
Nut	70
Injection pump bolt	22.5
Bolt	20
Pistons and connecting rods	
Connecting rod cap bolt	45
Flywheel	
Flywheel bolt	53
Crankshaft and cylinder block	
Main bearing cap bolt	65
Front plate bolt	12.5

FORM-IN-PLACE GASKET

The engine has several areas where the form-in-place gasket (FIPG) is in use. To ensure that the gasket fully serves its purpose, it is necessary to observe some precautions when applying the gasket. Bead size, continuity and location are of paramount importance. Too thin a bead could cause leaks. Too thick a bead, on the other hand, could be squeezed out of location, causing blocking or narrowing of the fluid feed line. To eliminate the possibility of leaks from a joint, therefore, it is absolutely necessary to apply the gasket evenly without a break, while observing the correct bead size.

The FIPG used in the engine is a room temperature vulcanization (RTV) type. Since the RTV hardens as it reacts with the moisture in the atmospheric air, it is normally used in the metallic flange areas.

Disassembly

The parts assembled with the FIPG can be easily disassembled without use of a special method. In some cases, however, the sealant between the joined surfaces may have to be broken by lightly striking with a mallet or similar tool. A flat and thin gasket scraper may be lightly hammered in between the joined surfaces. In this case, however, care must be taken to prevent damage to the joined surfaces. For removal of the oil pan, the special tool "Oil Pan Remover" is available. Be sure to use the special tool to remove the oil pan.

Surface Preparation

Thoroughly remove all substances deposited on the gasket application surfaces, using a gasket scraper or wire brush. Check to ensure that the surfaces to which the FIPG is to be applied is flat. Make sure that there are no oils, greases and foreign substances deposited on the application surfaces. Do not forget to remove the old sealant remained in the bolt holes.



Form-In-Place Gasket Application



When assembling parts with the FIPG, you must observe some precautions, but the procedure is very simple as in the case of a conventional pre-cut gasket.

Applied FIPG bead should be of the specified size and without breaks. Also be sure to encircle the bolt hole circumference with a completely continuous bead. The FIPG can be wiped away unless it is hardened. While the FIPG is still moist (in less than 15 minutes), mount the parts in position. When the parts are mounted, make sure that the gasket is applied to the required area only. In addition, do not apply any oil or water to the sealing locations or start the engine until a sufficient amount of time (about one hour) has passed after installation is completed.

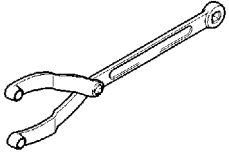
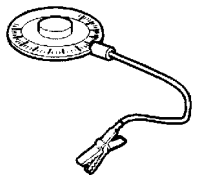
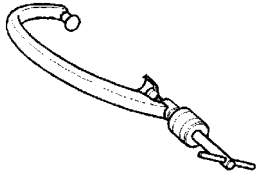
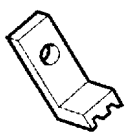
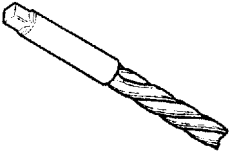
The FIPG applications procedure may vary on different areas. Observe the procedure described in the text when applying the FIPG.

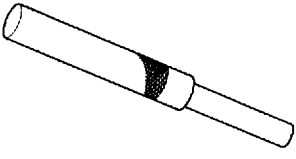
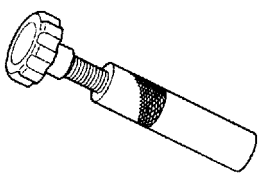
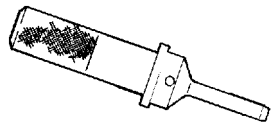
2. SPECIAL TOOLS

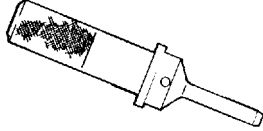
Tool	Number	Name	Use
	MB990767	Camshaft sprocket holder	Removal of camshaft sprocket
	MB991614	Angle gauge	Tightening cylinder head bolts
	MB996014	Valve spring compressor	Removal of valve spring split cones
	MB996015	Flywheel stopper	Locking the flywheel
	MB996016	Reamer	Reaming valve guides
	MB996018	Slip gauge	Measuring the crankshaft end play
	MB996020	Valve guide remover	Pressing in valve guides
	MB996021	Valve stem seal remover	Removal of valve guide seal
	MB996022	Valve seat installer	Pressing in intake valve seat

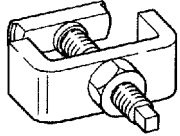
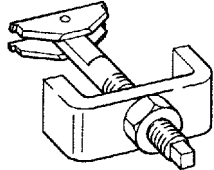
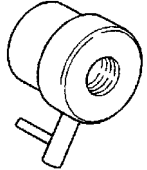
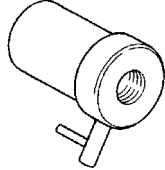
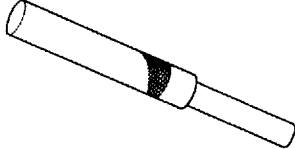
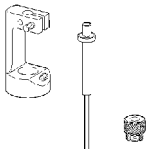
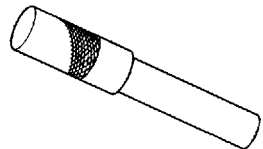
Tool	Number	Name	Use
	MB996023	Valve seat installer	Pressing in intake valve seat
	MB996024	Reamer	Reaming valve guides
	MB996025	Bearing puller	Removal of intermediate shaft outer bearing
	MB996026	Bearing puller	Removal of intermediate shaft inner bearing
	MB996027	Bearing installer	Installation of intermediate shaft inner bearing
	MB996028	Bearing installer	Installation of intermediate shaft outer bearing
	MB996029	Valve guide installer	Pressing in valve guides
	MB996030	Measuring device adapter	Adjustment of fuel injection pump
	MB996031	Valve stem seal installer	Installation of valve guide seal

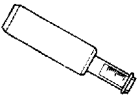
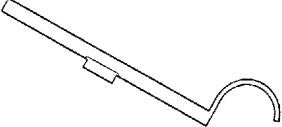
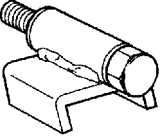
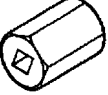
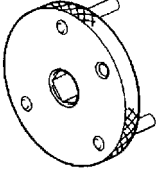
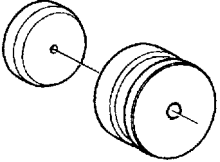
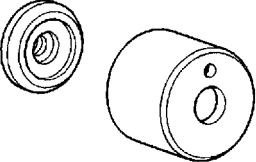
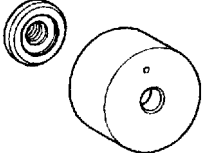
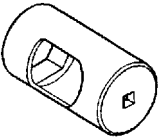
Tool	Number	Name	Use
	MB996032	Tension gauge	Measuring timing belt deflection
	MB996033	Tension gauge	Measuring timing belt deflection
	MB996034	Sprocket stopper	Removal of intermediate shaft sprocket
	MB996036	Hexagon socket	Removal of injection pump sprocket screwed sleeve/nut assembly
	MB996037	Sprocket adapter	Adjustment of fuel injection pump
	MB996038	Oil seal installer	Installation of crankshaft oil seal (flywheel end)
	MB996039	Oil seal installer	Installation of intermediate shaft oil seal
	MB996040	Oil seal installer	Installation of crankshaft oil seal (timing gear end)
	MB996041	Special socket	Removal of fuel injectors

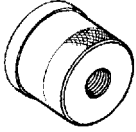
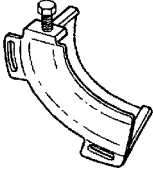
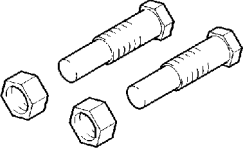
Tool	Number	Name	Use
	MB996042	Oil seal installer	Installation of camshaft oil seal
	MB996043	Sprocket stopper	Locking the injection pump sprocket
	MD998715	Pulley holder pin	Retaining the camshaft sprocket (use together with MB990767)

3. CRANKSHAFT PULLEY

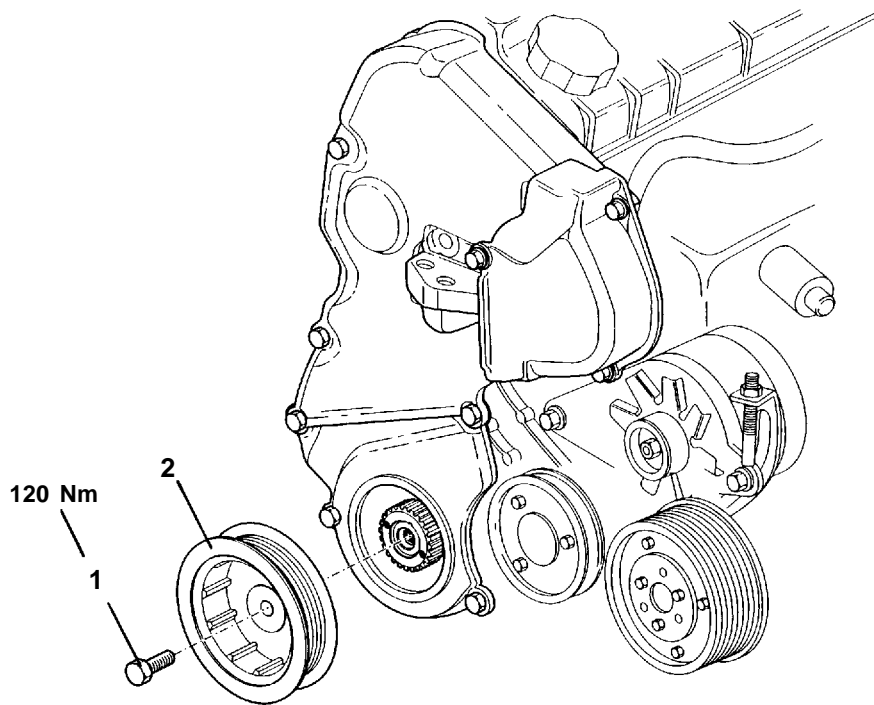

REN0143

Removal steps



1. Crankshaft pulley bolt
2. Crankshaft pulley

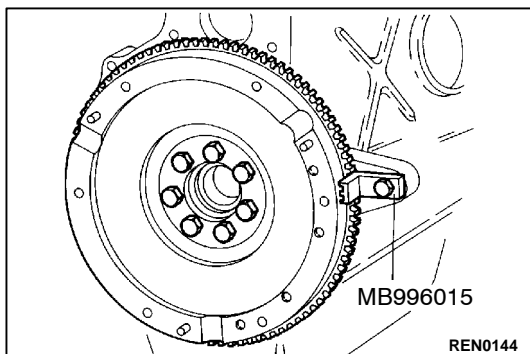

REMOVAL SERVICE POINT

◀A▶ CRANKSHAFT PULLEY BOLT REMOVAL

Use special tool MB996015 to hold the flywheel during removal.

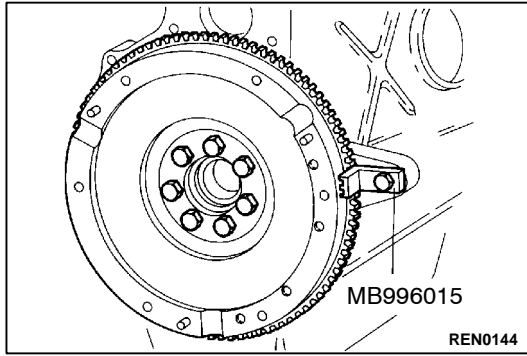

INSTALLATION SERVICE POINT

▶A◀ CRANKSHAFT PULLEY INSTALLATION

(1) Use special tool MB996015 to hold the flywheel during installation.

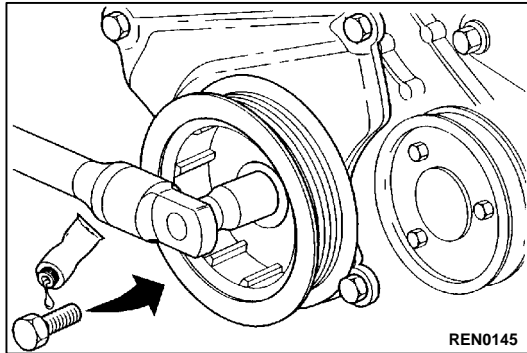

(2) Apply a locking agent to the screw thread of the bolt. Tighten the bolt to the specified torque.

4. TIMING BELT



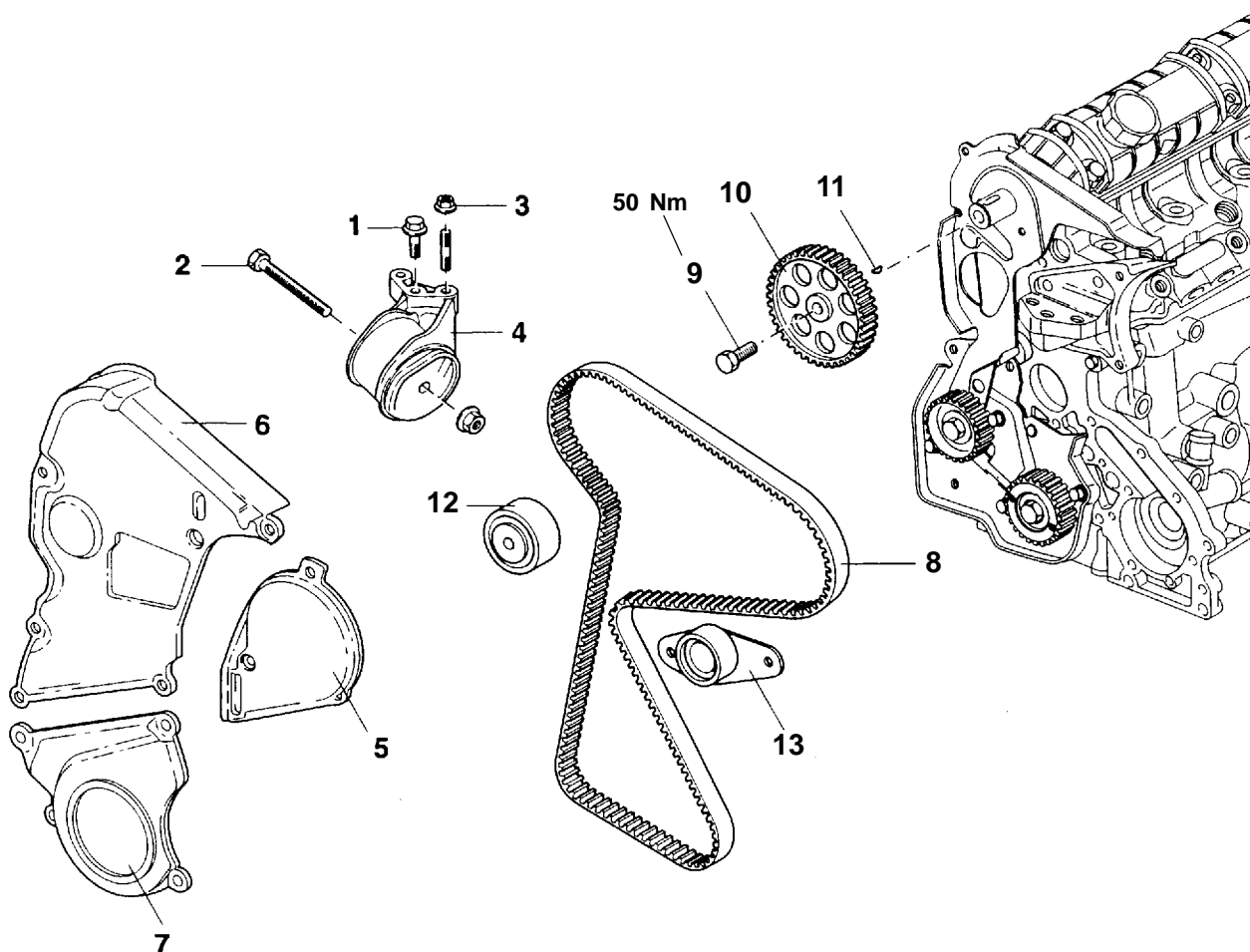

REMOVAL AND INSTALLATION



REN0001

Removal steps

1. Bolt
2. Bolt
3. Nut
4. Engine support bracket
5. Timing gear case cover
6. Timing gear case cover
7. Timing gear case cover

- | | | |
|---|---|---------------------------|
|  |  | 8. Timing belt |
|  |  | 9. Camshaft sprocket bolt |
| | | 10. Camshaft sprocket |
| | | 11. Camshaft sprocket key |
| | | 12. Timing belt tensioner |
| | | 13. Timing belt idler |

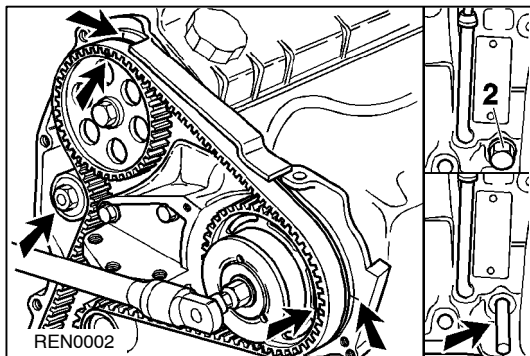

REMOVAL SERVICE POINTS

◀A▶ TIMING BELT REMOVAL

- (1) Turn the crankshaft clockwise so that the piston of No. 1 cylinder (flywheel end) is at TDC, with the following marks in line with each other:
 - flywheel/clutch housing;
 - rear guard plate/camshaft sprocket.
 Scribe a mark on the injection pump mounting bracket.
- (2) Insert an 8 mm diameter locking pin in the threaded hole of torx bolt 2 so that it engages the recess in the crankshaft web.
- (3) Slacken the lock nut of the timing belt tensioner. Remove the timing belt.

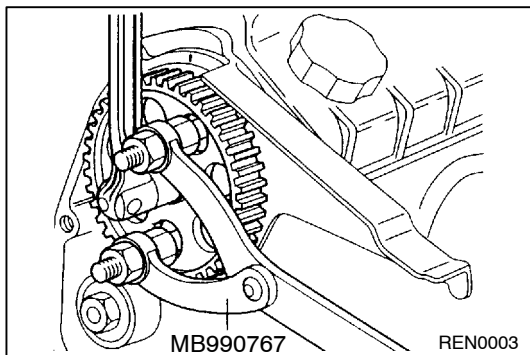

◀B▶ CAMSHAFT SPROCKET BOLT REMOVAL

- (1) Use special tool MB990767, camshaft sprocket holder with pin MD998715 and remove the retaining bolt.

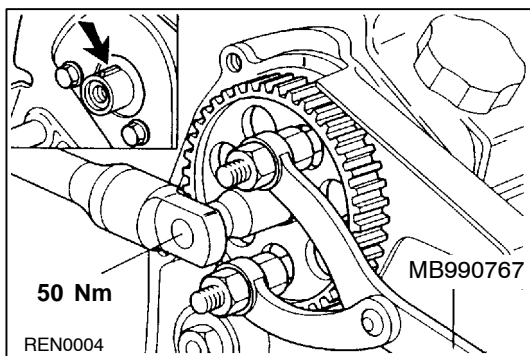

INSTALLATION SERVICE POINTS

▶A▶ CAMSHAFT SPROCKET BOLT INSTALLATION

- (1) Smear the retaining bolt with a locking agent. Use special tool MB990767, camshaft sprocket holder with pin MD998715 to stop the sprocket turning and then tighten the camshaft sprocket retaining bolt to 50 Nm.

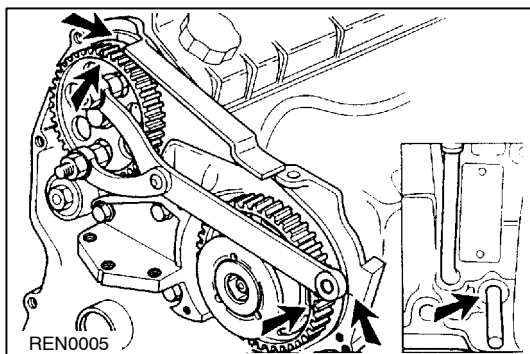

▶B▶ TIMING BELT INSTALLATION

- (1) Turn the camshaft clockwise with special tool MB990767 until the mark on the camshaft sprocket is opposite the mark on the guard plate.
- (2) Turn the crankshaft 1/4 revolution counter-clockwise from the TDC position of No. 1 cylinder and insert the 8 mm diameter locking pin in the recess in the crankshaft web.
- (3) Align the mark on the injection pump sprocket with the mark on the mounting bracket (turn clockwise).

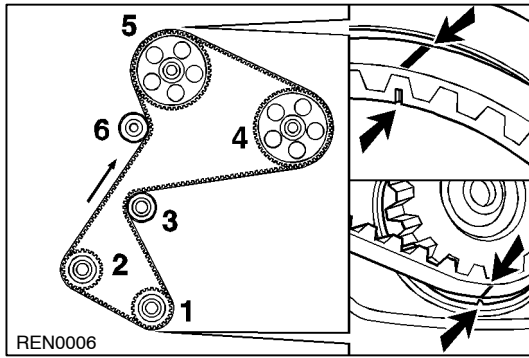

- (4) Fit the timing belt so that the lines on the belt are aligned with the marks on the crankshaft and camshaft sprockets and the injection pump sprocket.

NOTE

- the direction of rotation of the belt (see the arrows on the belt);
- the sequence in which the belt is fitted around the sprockets.

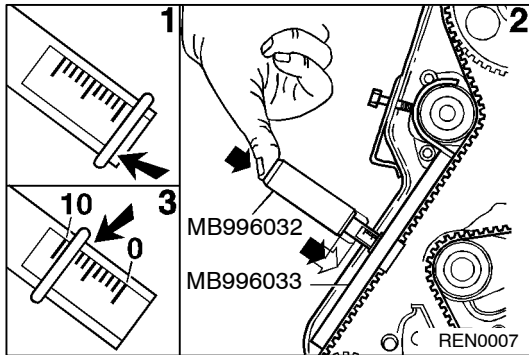

- (5) Fit the special tool on the timing belt and the timing belt tensioner.

- (6) Tension the timing belt with the aid of an M6 bolt.

Standard value: 7.5 mm

- (7) Tighten the lock nut to the specified torque.

INSPECTION

TIMING BELT

Should either of the following defects be evident, replace the belt with a new one:

- (1) Hardened back surface rubber.
Glossy, non-elastic and so hard that no mark is produced when scratched with a fingernail.

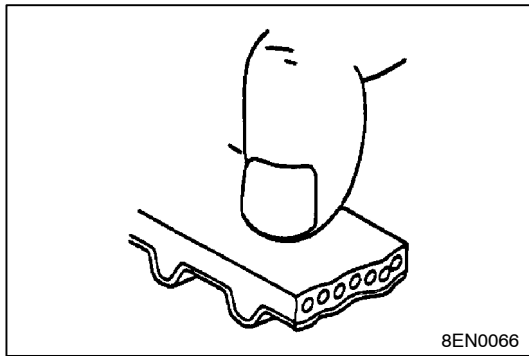

- (2) Cracked back surface rubber.
(3) Cracked or separated canvas.
(4) Cracked tooth bottom.
(5) Cracks in back surface of belt.

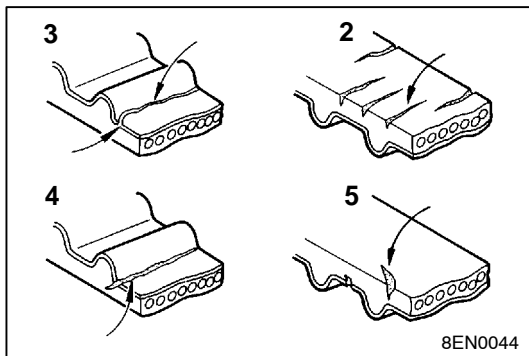

- (6) Abnormal wear on the sides of the belt. A normal belt should have clear-cut sides as if cut by a sharp knife.

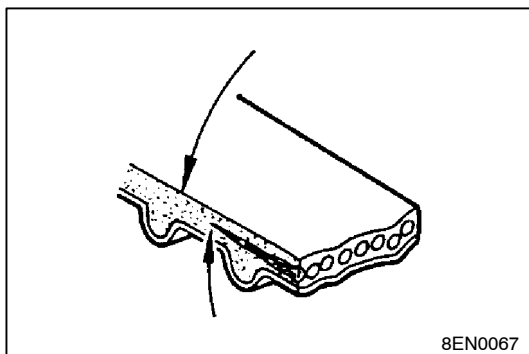

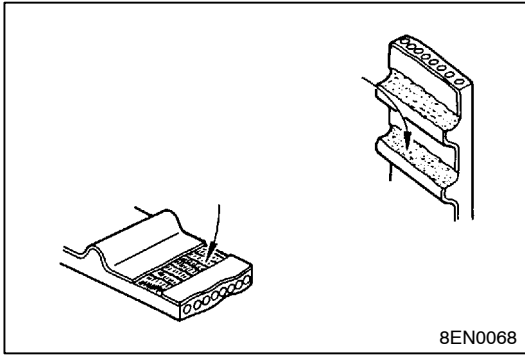

- (7) Abnormal wear in teeth.
- (8) Missing tooth.

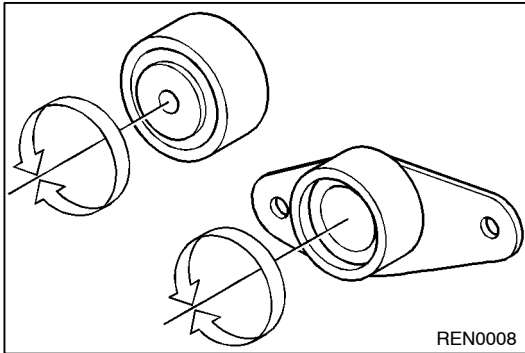

TIMING BELT TENSIONER AND IDLER

- (1) Check that the tensioner and idler rotate smoothly without excessive play or abnormal noise. Replace them with new ones if necessary.

5. WATER PUMP

REMOVAL AND INSTALLATION

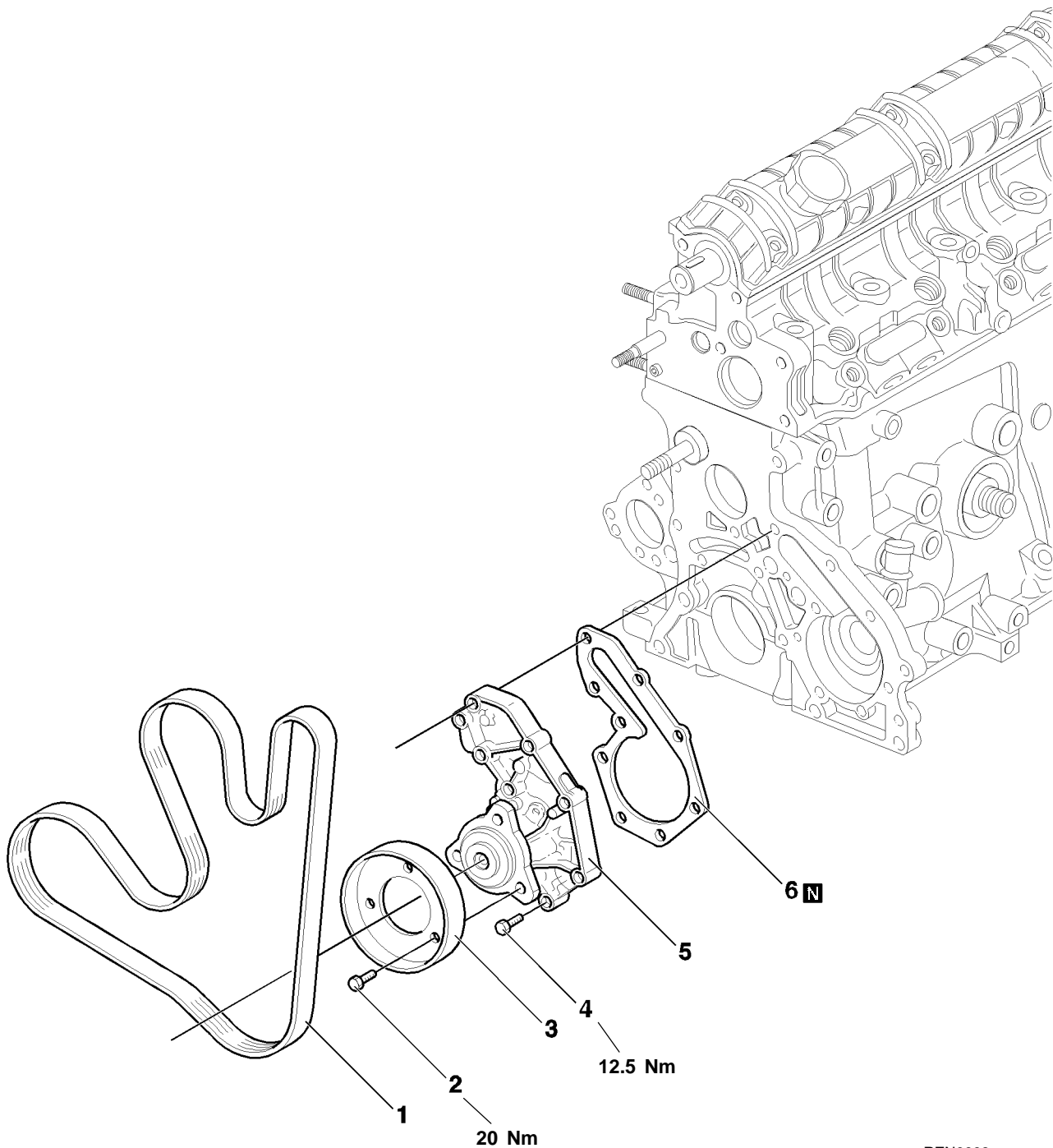

Removal steps

1. V-ribbed belt (alternator & others)
2. Bolt
3. Water pump pulley
4. Bolt
5. Water pump
6. Water pump gasket

6. THERMOSTAT

REMOVAL AND INSTALLATION

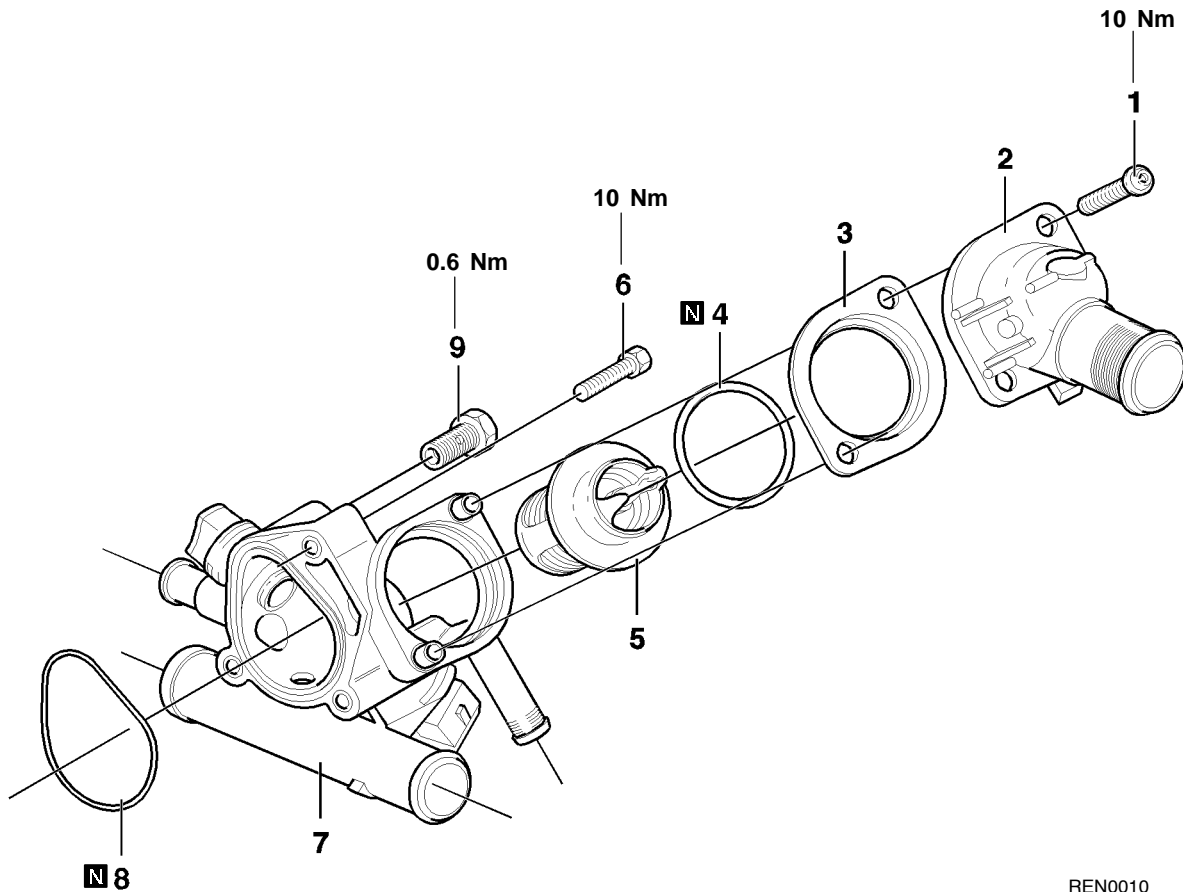

REN0010

Removal steps

1. Bolt
2. Thermostat cover
3. Plate
- ▶A◀ 4. O-ring
5. Thermostat
6. Bolt
- ▶A◀ 7. Thermostat housing
8. O-ring
9. Bleedscrew

INSTALLATION SERVICE POINT

▶A◀ O-RING INSTALLATION

Caution

- If O-rings are soaked in engine oil they will swell up. Keep the O-rings 4 and 8 free of engine oil when they are being fitted.

7. WATER HOSES AND PIPES

REMOVAL AND INSTALLATION

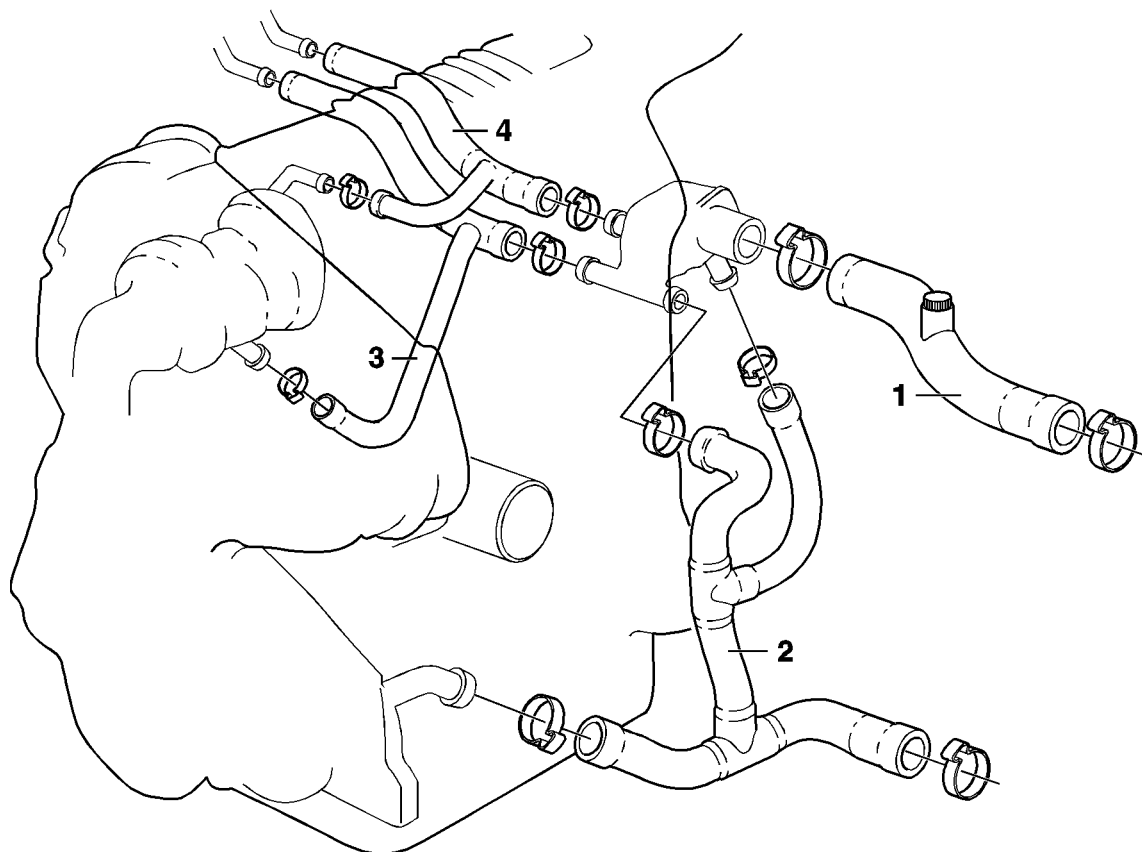

REN0035

Removal steps

1. Water inlet hose
2. Water outlet hose
3. Heater inlet hose
4. Heater outlet hose

8. ENGINE COOLANT TEMPERATURE SENSOR

REMOVAL AND INSTALLATION

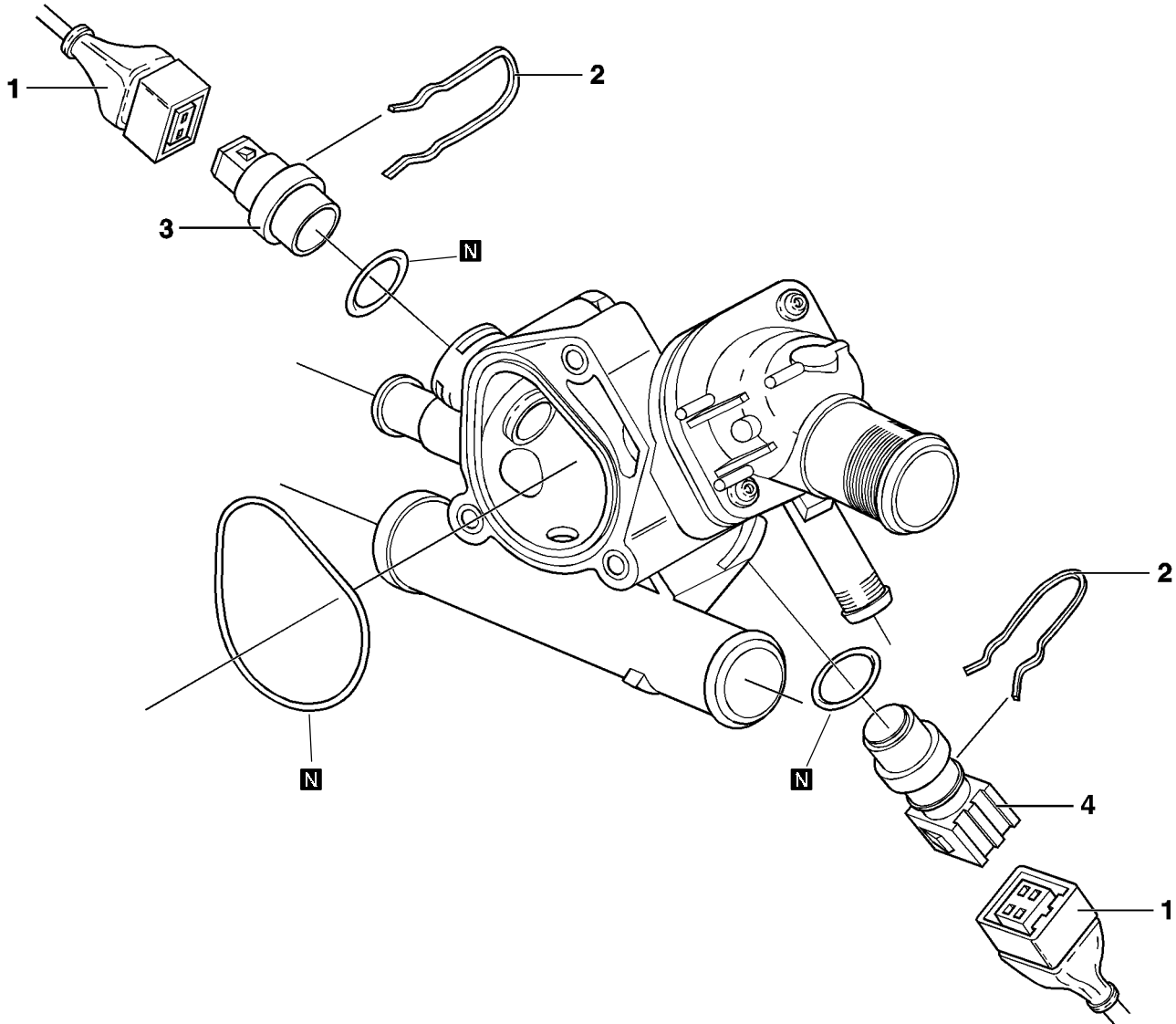

REN0036

Removal steps

1. Wiring harness connector
2. Retaining clip
3. Temperature sensor, ECU
4. Temperature sensor, instrument panel

9. GLOW PLUGS

REMOVAL AND INSTALLATION

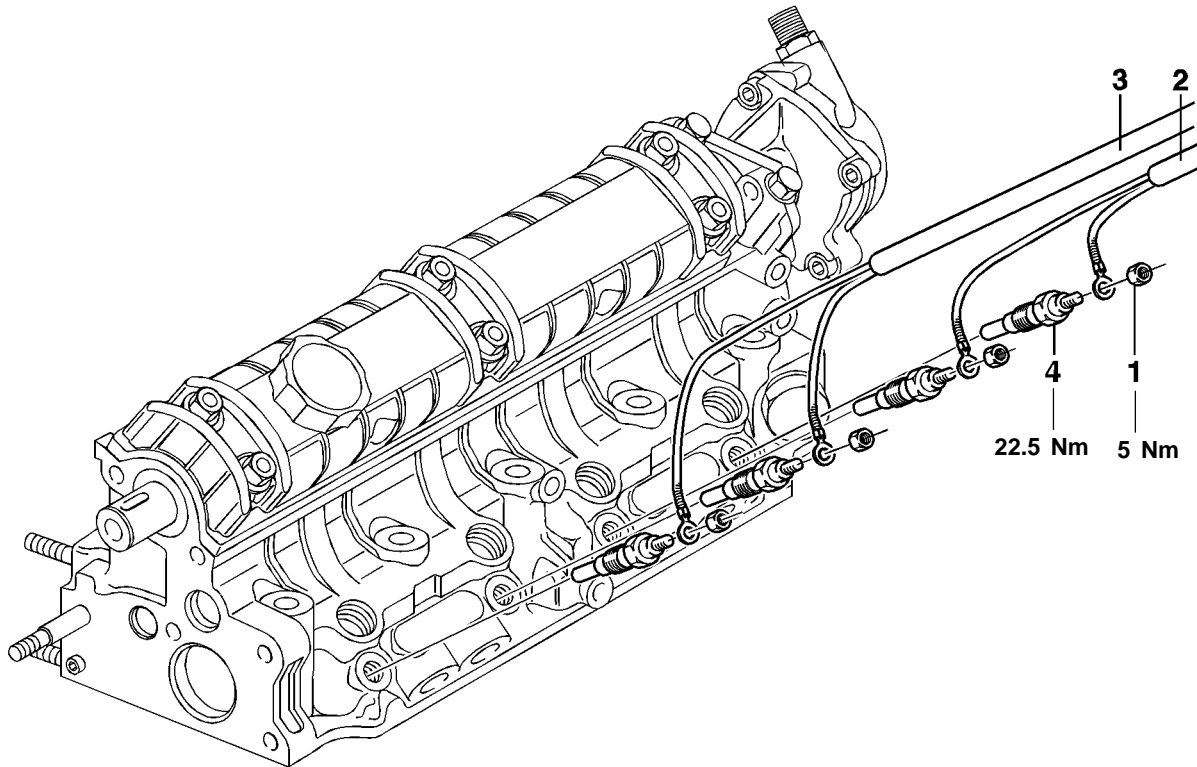

REN0037

Removal steps

1. Nut
2. Glow plug leads, Nos. 1 and 2
3. Glow plug leads, Nos. 3 and 4
4. Glow plug

10. TURBOCHARGER

REMOVAL AND INSTALLATION

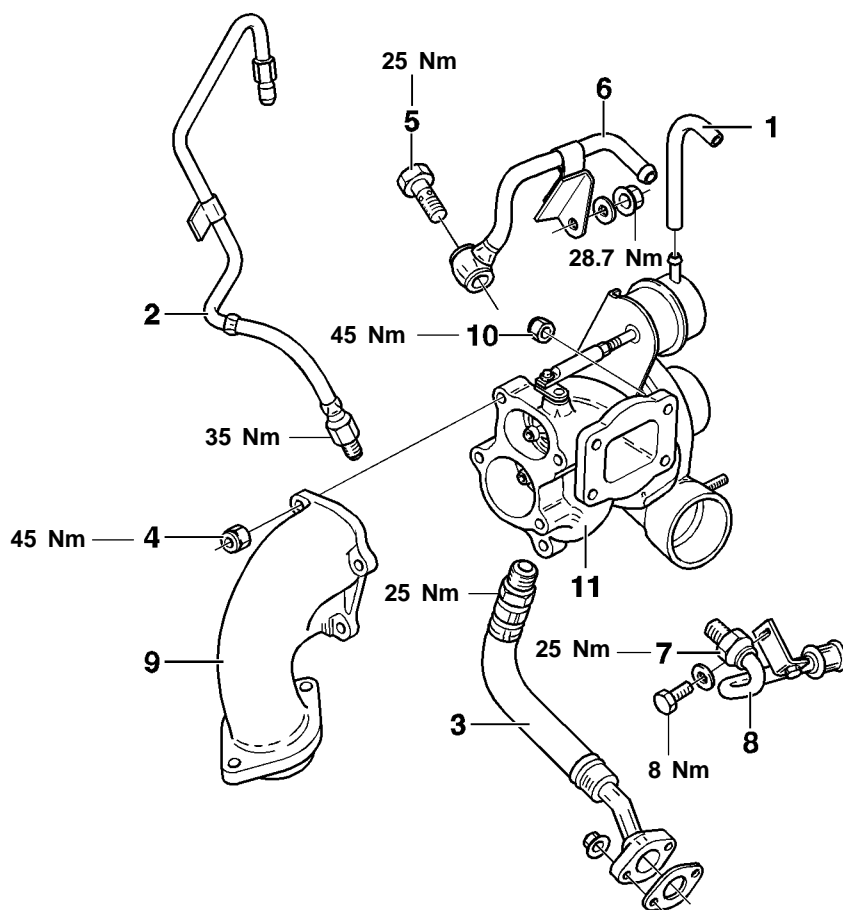

REN0038

Removal steps

1. Vacuum hose
2. Oil supply pipe
3. Oil return pipe
4. Nut
5. Banjo bolt
6. Coolant supply pipe

7. Union nut
8. Coolant discharge pipe
9. Connector-to-exhaust downpipe
10. Nut
- ▶A◀ 11. Turbocharger unit

INSTALLATION SERVICE POINTS

▶A◀ TURBOCHARGER INSTALLATION

- (1) Before fitting the turbocharger lubricate the parts with engine oil introduced through oil filler opening.

11. INTAKE AND EXHAUST MANIFOLDS

REMOVAL AND INSTALLATION

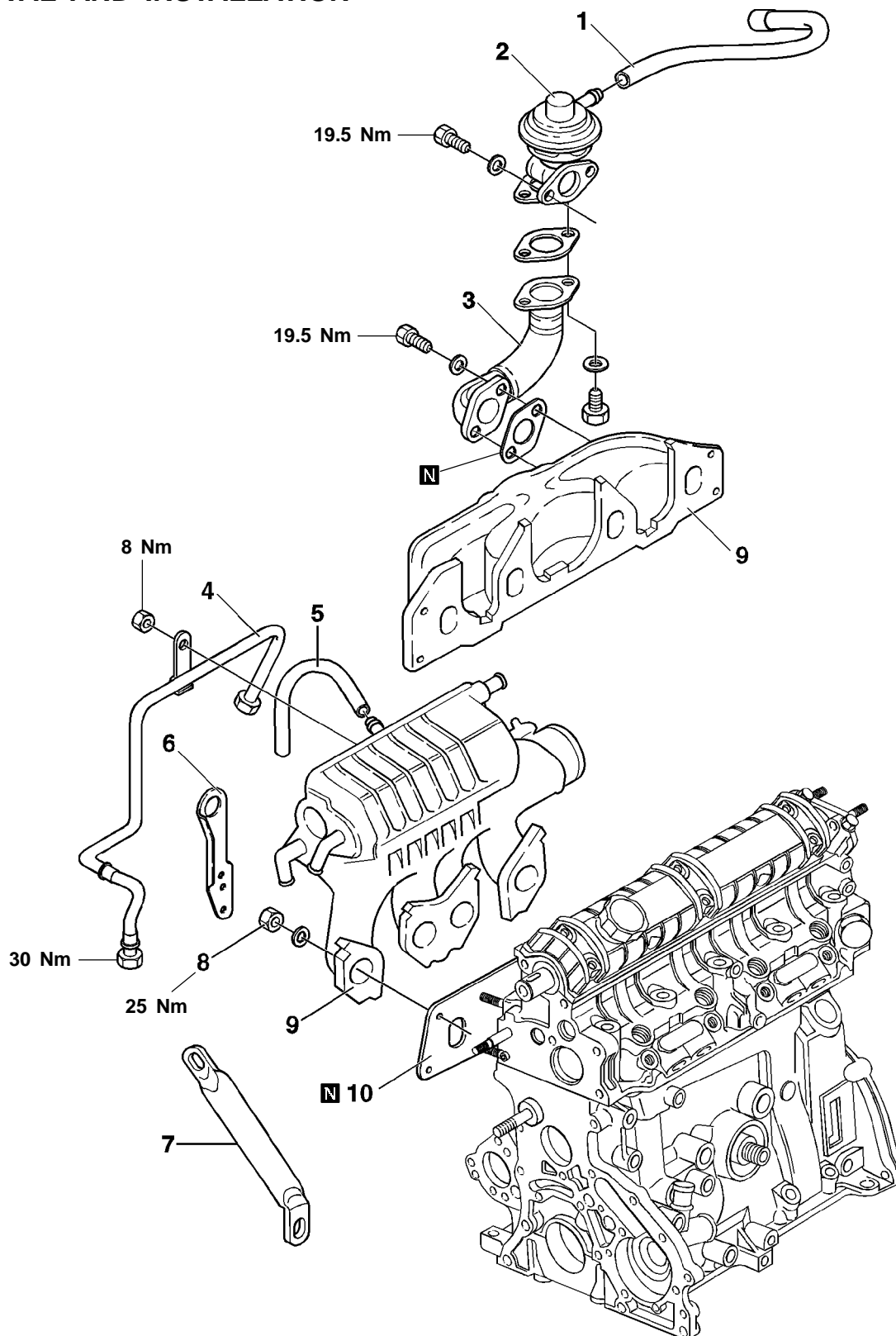

REN0039

Removal steps

- | | |
|--------------------------------|---------------------------------|
| 1. Vacuum hose | 6. Engine hanger |
| 2. EGR valve | 7. Bracket |
| 3. EGR pipe | 8. Nuts |
| 4. Oil pipe from turbocharger | 9. Intake and exhaust manifolds |
| 5. Vacuum hose to turbocharger | 10. Gasket |

12. ROCKER COVER AND CYLINDER HEAD

REMOVAL AND INSTALLATION

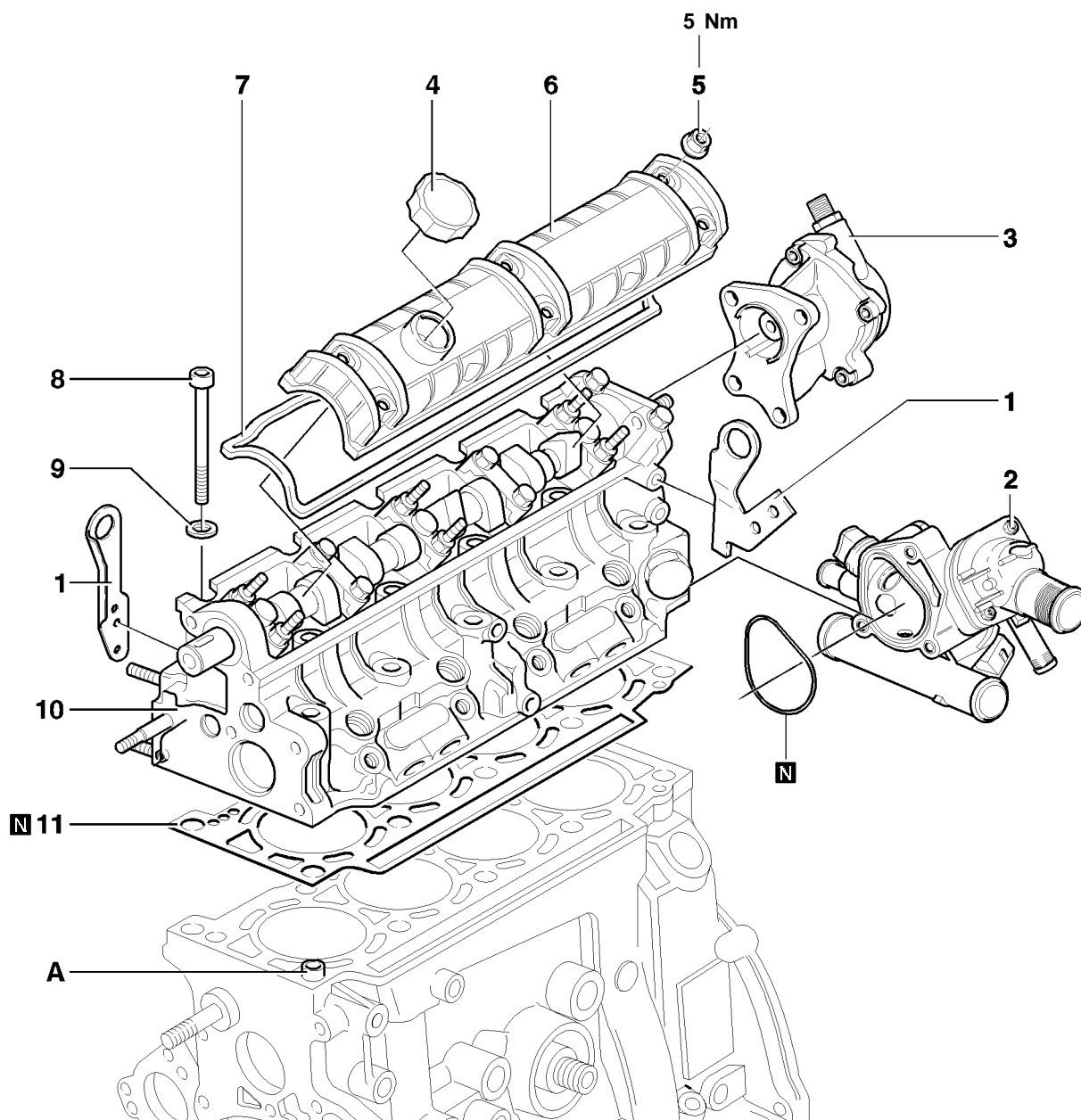

REN0040

Removal steps

1. Engine hanger
2. Thermostat housing
3. Vacuum pump
4. Oil filler cap
5. Nut
6. Rocker cover
7. Rocker cover gasket

- ▶C◀ 8. Cylinder head bolt
 9. Washer

- ◀A▶ ▶B◀ 10. Cylinder head
 ▶B▶ ▶A◀ 11. Cylinder head gasket

A: Locating dowel



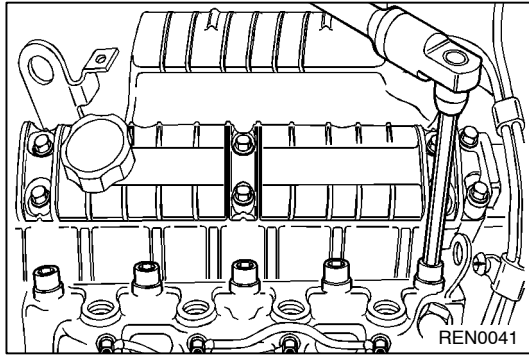

REMOVAL SERVICE POINTS

◀A▶ CYLINDER HEAD REMOVAL

- (1) Release and then remove the cylinder head bolts.
- (2) Lift the cylinder head straight up over the locating dowels and then remove the cylinder head.

◀B▶ CYLINDER HEAD GASKET REMOVAL

Caution

- When removing the cylinder head gasket, take care not to scratch the cylinder head or cylinder block gasket faces.

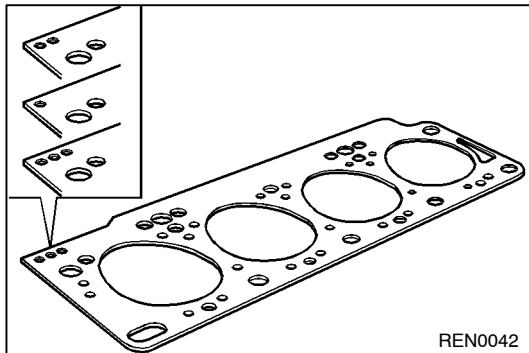

INSTALLATION SERVICE POINTS

▶A◀ CYLINDER HEAD GASKET INSTALLATION

- (1) Select a cylinder head gasket of the correct thickness according to the projecting height of the pistons. The available cylinder head gaskets are shown in the table below. The thickness of the gasket is indicated by the number of holes near the end of the gasket (see the illustration). Measure the projecting height of the pistons and calculate the average height. Then select a cylinder head gasket of the correct thickness from the table shown below.

Piston height above cylinder block mm	Number of holes	Gasket thickness mm
- 0.073	2	1.40
0.073 - 0.206	1	1.50
0.206 -	3	1.60

When only the gasket is to be replaced, check the hole pattern on the old gasket and select a gasket with the same number of holes.

Caution

- If a piston or connecting rod, etc. has been replaced, always measure the projecting height of the pistons because this may have changed after replacing these parts.

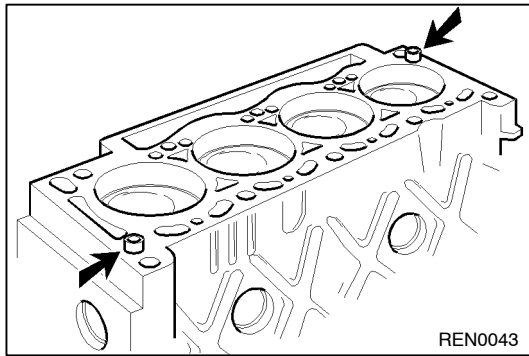

REN0043

►B◄ CYLINDER HEAD INSTALLATION

- (1) Select a suitable cylinder head gasket 11.
- (2) Rotate the crankshaft so that the piston of No. 1 cylinder is positioned a quarter-stroke past TDC.
- (3) Fit the cylinder head over the locating dowels.

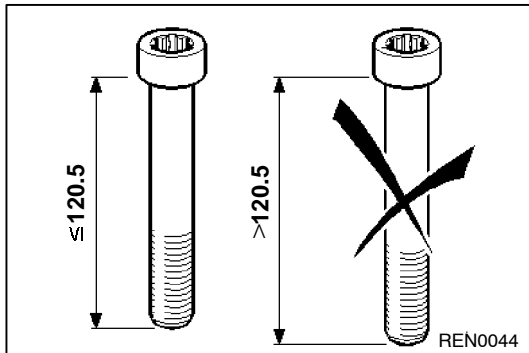

REN0044

►C◄ CYLINDER HEAD BOLT INSTALLATION

- (1) When installing the cylinder head bolts, check that the length of the shank of each bolt (without the washer) is within the limit value. All the cylinder head bolts must be renewed as soon as any of them exceeds the permitted length.

Limit: max. 120.5 mm

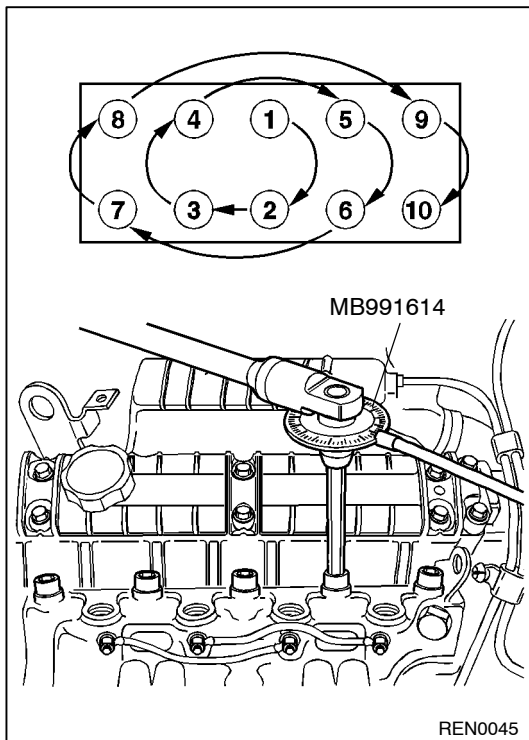

REN0045

- (2) Fit the washers.
- (3) Lubricate the bolt threads and washers with engine oil.
- (4) Insert the cylinder head bolts and fasten them finger-tight. The cylinder head bolts should be torque-tightened in three stages.

Tighten in the first stage:

- first to 30 Nm;
- then angle-tighten to $50^\circ \pm 4^\circ$ in a single uninterrupted movement.

NOTE

Wait at least three minutes to allow the head gasket to bed down properly.

- (5) Now slacken all the bolts completely.
- (6) Then tighten to the second stage torque:
 - first to 25 Nm;
 - then angle-tighten the bolts to $213^\circ \pm 7^\circ$ in a single uninterrupted movement.

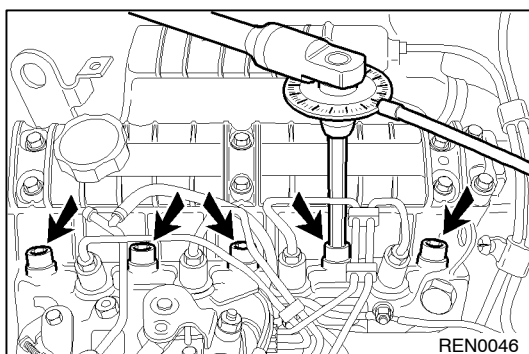

REN0046

- (7) The cylinder head can only be retorqued after letting the engine warm up to its operating temperature. Tightening torque for the third stage:
 - let the engine warm up (engine cooling fan starts to turn);
 - then angle-tighten the cylinder head bolts to $120^\circ \pm 7^\circ$ in a single uninterrupted movement.

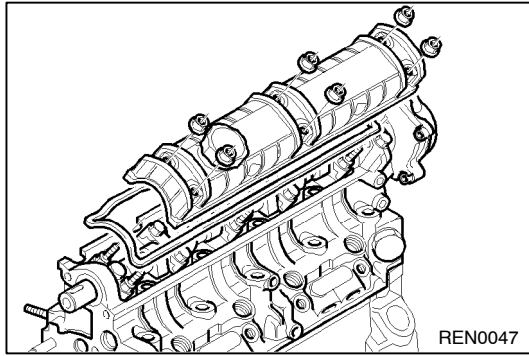
**►D◄ ROCKER COVER GASKET INSTALLATION**

- (1) Lightly smear the corners of the rocker cover gasket with a sealant.
- (2) Locate the gasket on the rocker cover.
- (3) Fit the rocker cover.

Caution

- **Make sure the gasket is still properly located.**

13. CAMSHAFT, INTAKE AND EXHAUST VALVES

REMOVAL AND INSTALLATION

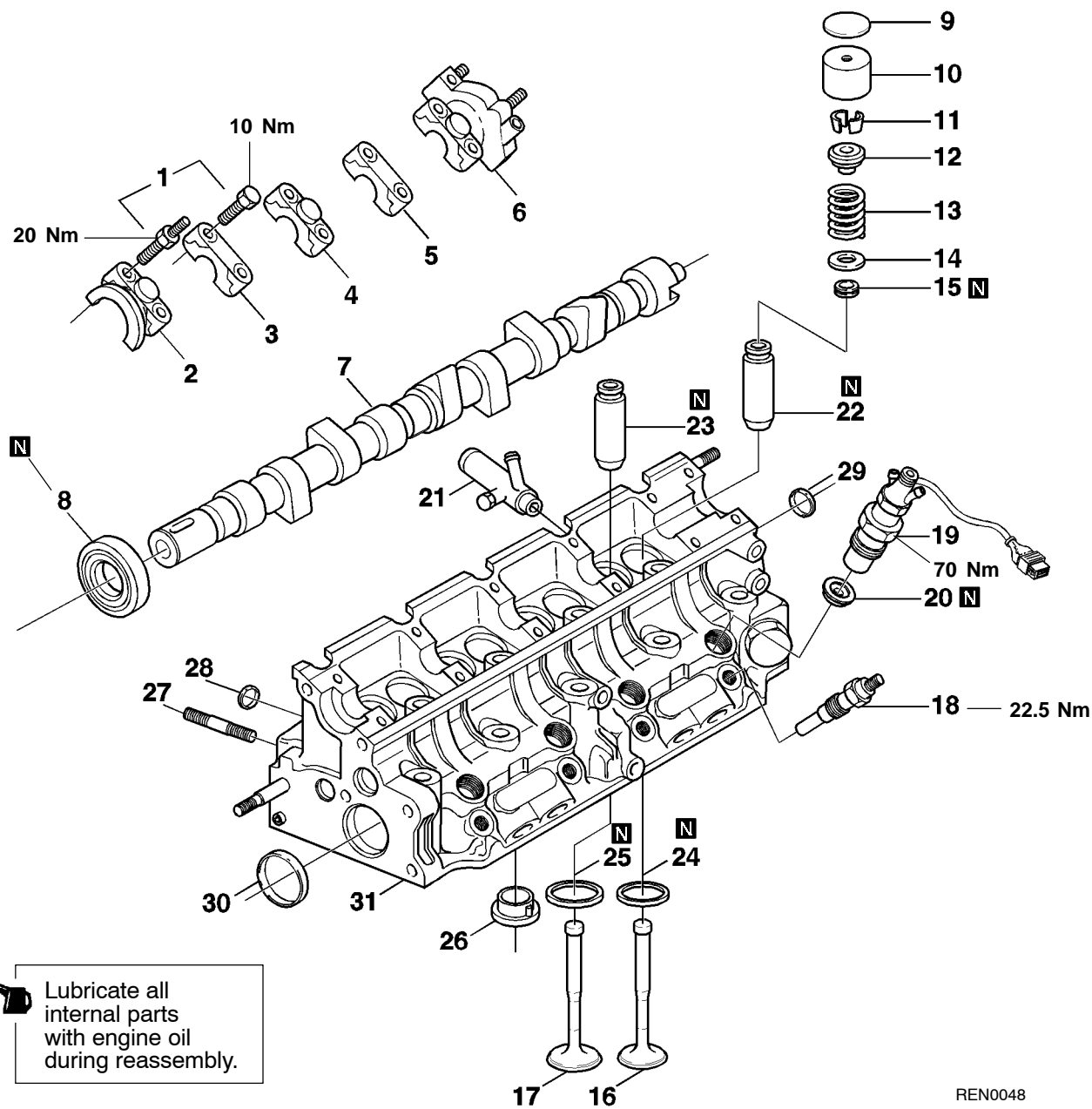

Lubricate all internal parts with engine oil during reassembly.

REN0048

Removal steps

- | | | | |
|-----|-------------------------------|-----|-------------------------|
| | 1. Bolt | | 17. Exhaust valve |
| ▶F◀ | 2. No. 1 camshaft bearing cap | ▶C◀ | 18. Glow plug |
| ▶F◀ | 3. No. 2 camshaft bearing cap | ▶C◀ | 19. Injection nozzle |
| ▶F◀ | 4. No. 3 camshaft bearing cap | ▶D◀ | 20. Shield |
| ▶F◀ | 5. No. 4 camshaft bearing cap | ▶D◀ | 21. Water pipe |
| ▶F◀ | 6. No. 5 camshaft bearing cap | ▶E◀ | 22. Intake valve guide |
| | 7. Camshaft | ▶B◀ | 23. Exhaust valve guide |
| ▶H◀ | 8. Oil seal | ▶B◀ | 24. Intake valve seat |
| | 9. Tappet pad | ▶G◀ | 25. Exhaust valve seat |
| | 10. Tappet | | 26. Swirl camber |
| ◀A▶ | ▶E◀ | ▶A◀ | 27. Stud |
| | 11. Retainer locks | ▶A◀ | 28. Sealing plug |
| | 12. Valve spring retainer | ▶A◀ | 29. Sealing plug |
| | 13. Valve spring | ▶A◀ | 30. Sealing plug |
| ◀B▶ | ▶D◀ | | 31. Cylinder head |
| | 14. Valve spring collar | | |
| | 15. Valve stem seal | | |
| | 16. Intake valve | | |

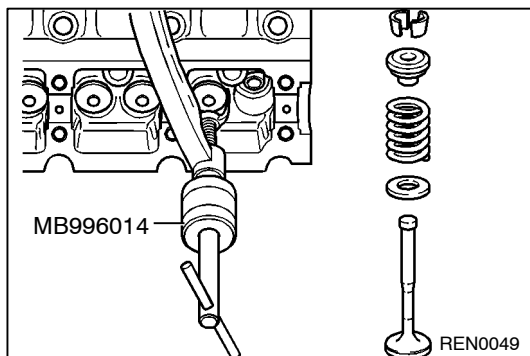
**REMOVAL SERVICE POINTS****◀A▶ RETAINER LOCKS REMOVAL**

- (1) Fit valve spring compressor MB996014 on the cylinder head **31** as shown in the illustration.
- (2) Press down the valve spring retainer **12** and remove the retainer locks **11**.

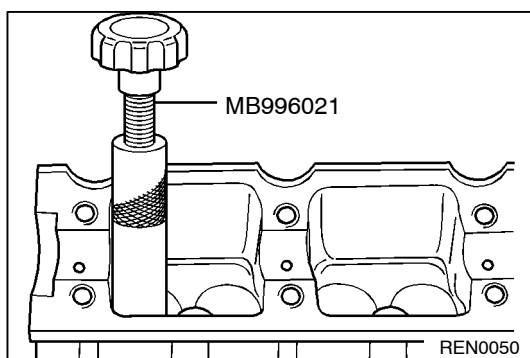
**◀B▶ VALVE STEM SEAL REMOVAL**

Remove the seal **15** with valve stem seal remover MB996021.

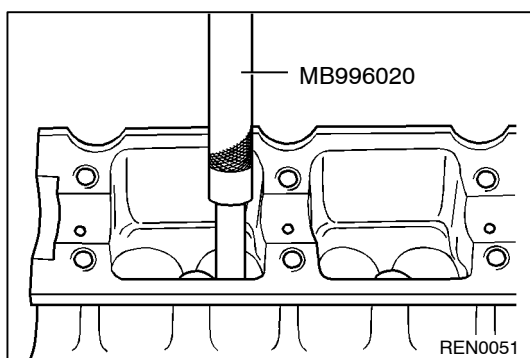
**◀C▶ VALVE GUIDE REMOVAL**

- (1) Support the cylinder head **31**.
- (2) Press out the valve guides **23, 23** towards the valve seat with valve guide remover MB996020.

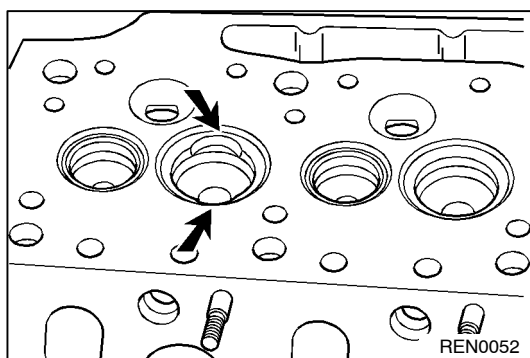
**◀D▶ VALVE SEAT REMOVAL**

- (1) Cut two recesses in the valve seats **24, 25**. The recesses are cut in order to lower the tension in the valve seat.

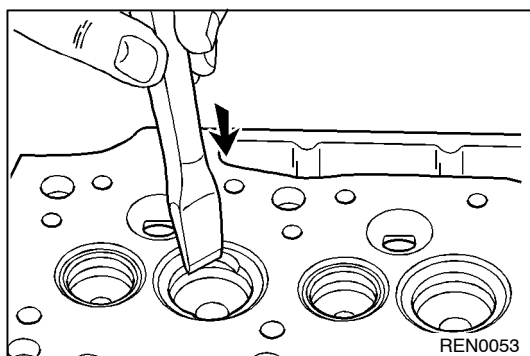

- (2) Break the valve seat into pieces with the aid of a cold chisel.

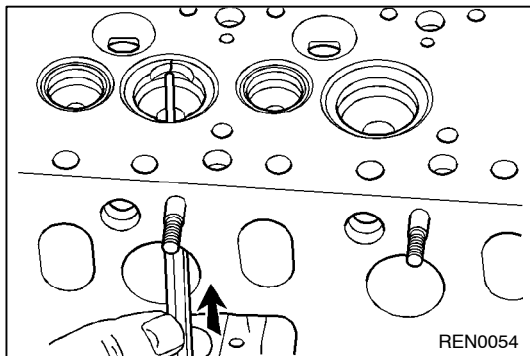

- (3) Tap the valve seat through the passage and out of the cylinder head using a long drift.

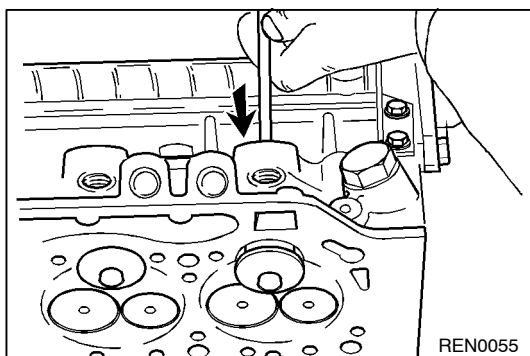

◀E▶ SWIRL CHAMBER REMOVAL

- (1) Insert a round rod in the glow plug hole. Remove the swirl chamber by tapping the rod with a hammer.

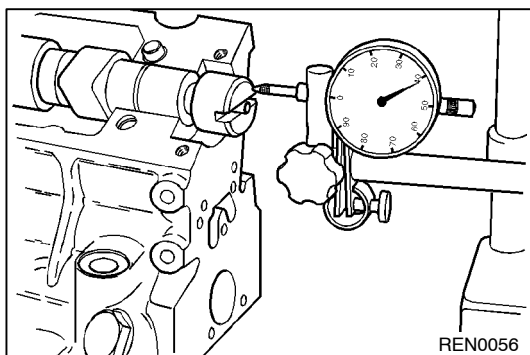

INSPECTION

CAMSHAFT

End play

- (1) Measure the end play. Fit a new cylinder head if the measured value deviates from the specified value.

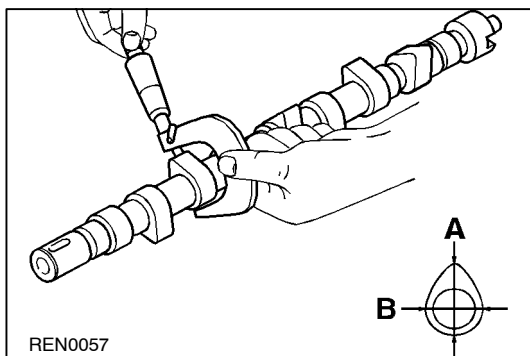

Difference between cam height and base circle diameter

- (1) Fit a new camshaft 7 if the limit value is exceeded.
 A: Cam height
 B: Base circle diameter

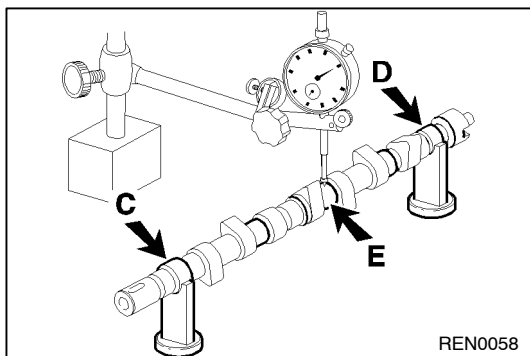

Radial play

- (1) Support the camshaft 7 at No. 1 journal C and No. 5 journal D and measure the warp at No. 3 journal E. Fit a new camshaft if the limit value is exceeded.

NOTE

The true warp is half of the value indicated by the dial indicator when the camshaft 7 is rotated once.

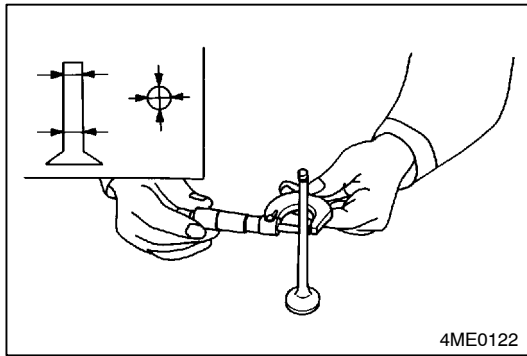

4ME0122

INTAKE AND EXHAUST VALVES

Examining the valve stem for wear

- Replace the valve if the valve stem diameter is smaller than the limit value or if there is evidence of uneven wear.

NOTE

If the valve **16, 17** is new, it should be matched with the valve seat **24, 25** by grinding them together.

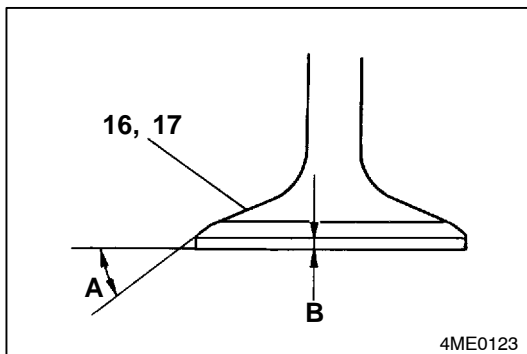

4ME0123

Valve seat angle and valve seat margin

- Replace the valve **16, 17** if the limit value is exceeded after correcting the valve seat angle.

A: Valve seat angle.

B: Valve seat margin.

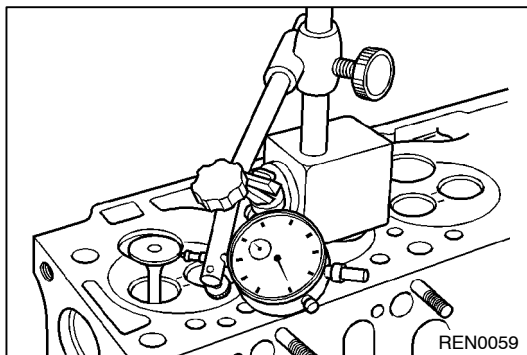

REN0059

VALVE AND VALVE GUIDE

- Replace the part in question if the clearance exceeds the limit value.

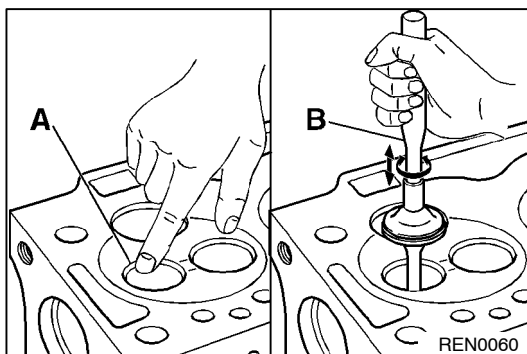

REN0060

VALVE AND VALVE SEAT

- Smear a layer of Minium evenly on the valve seating surface of the valve seats **24, 25**.
- Press the valve **16, 17** once against the valve seat **24, 25**, making sure that the valve does not rotate.

B: Grinding tool.

NOTE

Before checking the valve contact, examine the valve **16, 17** and the valve guide **22, 23** carefully to check whether their condition is normal.

- Determine the condition of the valve seat by means of the Minium pattern on the valve **16, 17**. If abnormal contact is established, take the following measures:

Small deviation: Grind the valve so that better contact is obtained.

Large deviation: Correct or replace the valve and valve seat.

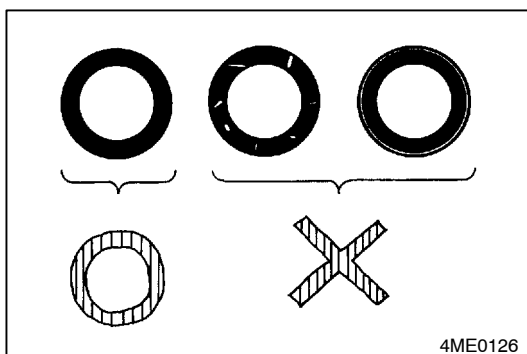

4ME0126

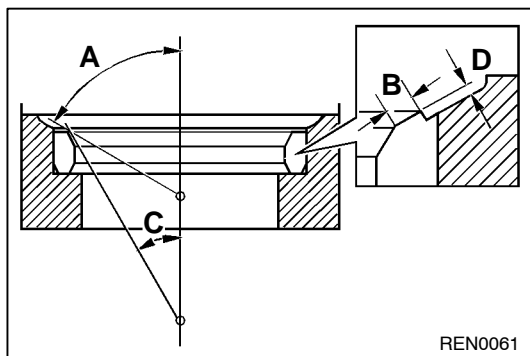

VALVE SEAT

Valve seat width

- (1) Replace the valve seat **24, 25** if the limit value is exceeded.

Angle **A**: intake valve seat: 60°
 exhaust valve seat: 45°

The contact surface **B** must be 1.7 ± 0.1 mm.
 If the contact surface is too wide, correct this with a valve seat cutter.

Cutter angle:

Angle **C**: intake valve seat: 45°
 exhaust valve seat: 30°

Caution

- The outside diameter of the cutter for the valve seat must not be more than:
 intake valve seat: 37.0 mm
 exhaust valve seat: 32.1 mm

After cutting, the dimension **D** must be 0.125 ± 0.025 mm.

NOTE

After correcting or replacing the valve seat **24, 25**, the valve seat and the valve **16, 17** should be matched by grinding them together in order to obtain correct seating.

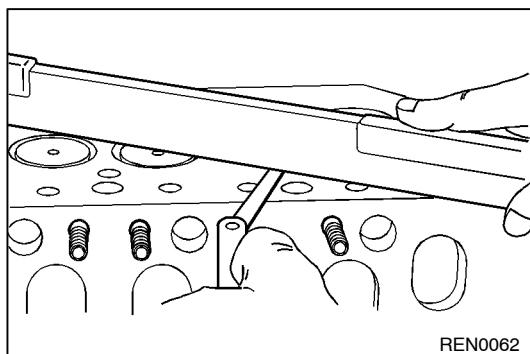

CYLINDER HEAD

- (1) Check the cylinder head gasket surface **31** for distortion.
 Fit a new cylinder head if the limit value is exceeded.

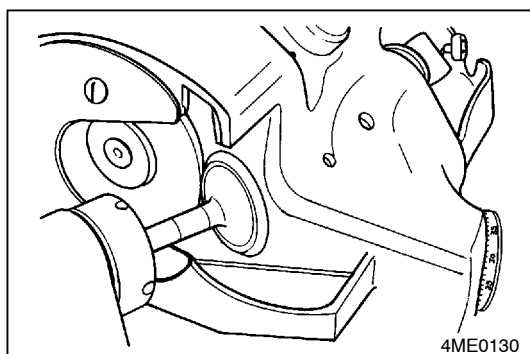

CORRECTION

INTAKE VALVE AND EXHAUST VALVE

Caution

- The amount of material removed by grinding should be restricted to a minimum.
- Replace the valve **16, 17** if the margin of the valve seat after grinding is smaller than the limit value.
- After the grinding operation, the valve **16, 17** should be matched with the valve seat **24, 25** by lapping them together in order to obtain correct seating.

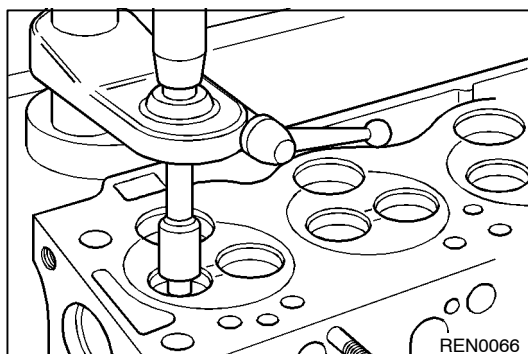
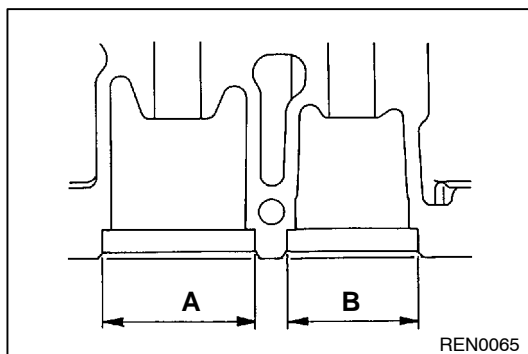
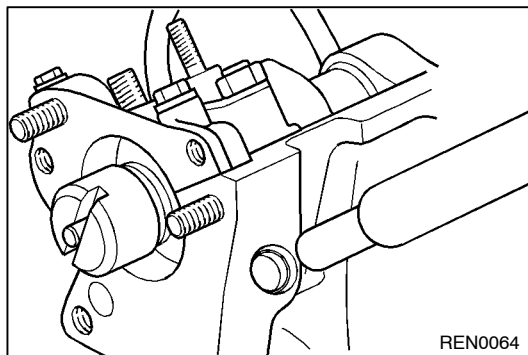
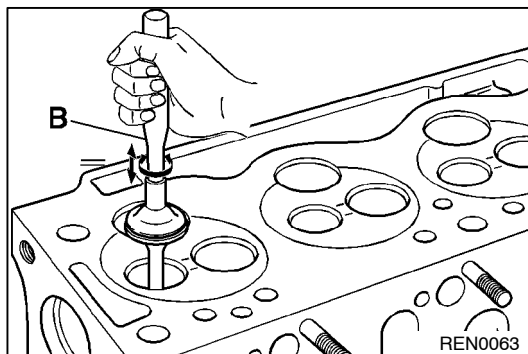
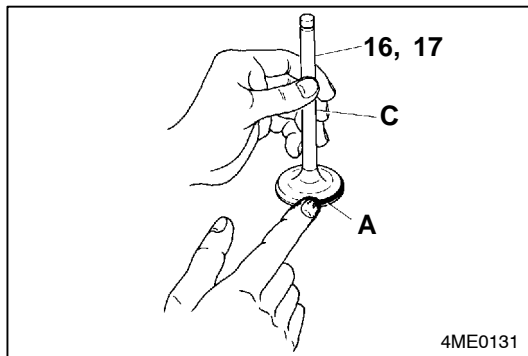

VALVE AND VALVE SEAT

- (1) The valve and the valve seat must be lapped as follows:
- Smear a thin layer of lapping compound evenly on the valve seating surface **A** of the valve seat **24, 25**.

Caution

- Make sure that no lapping compound is smeared on the stem **C** of the valve **16, 17**.
- First use an average grade lapping compound (120-150) and then a finer grade (more than 200).
- Mix the lapping compound with a small quantity of engine oil to facilitate even application.

- Tap the valve **16, 17** a few times with the grinding tool against the valve **24, 25** while continuing to rotate the tool slightly.

B: Grinding tool

- Remove the lapping compound with paraffin
- Coat the seating surface of the valve seat **24, 25** with a thin layer of engine oil in order to lap the valve and valve seat with oil.
- Inspect the contact surface between the valve **15, 16** and the valve seat **24, 25**.
- If necessary, replace the valve seat **24, 25**.

INSTALLATION SERVICE POINTS

►A◄ SEALING PLUG INSTALLATION

Drive in the sealing plugs **28, 29, 30** to the specified depth. When pressing in the sealing plugs **28, 29, 30** apply sealant (Loctite 648) to the corresponding holes in the cylinder head **31**.

►B◄ VALVE SEAT INSTALLATION

- Measure the diameter of the valve seat bores **A, B** in the cylinder head **31**. If a measured value does not come within the specified tolerance range, select an oversize valve seat from the table below.

Standard value:

Intake valve A = 37 mm diam.

Exhaust valve B = 32.1 mm diam.

- Ream the valve seat bores **A, B** in the cylinder head to the outside diameter of the selected oversize valve seats.

Oversize valve seats:

Intake valve diameter 37.3 mm

Exhaust valve diameter 32.4 mm

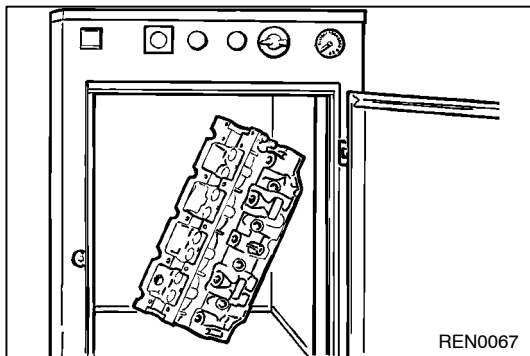

(3) Heat the cylinder head to about +100°C.

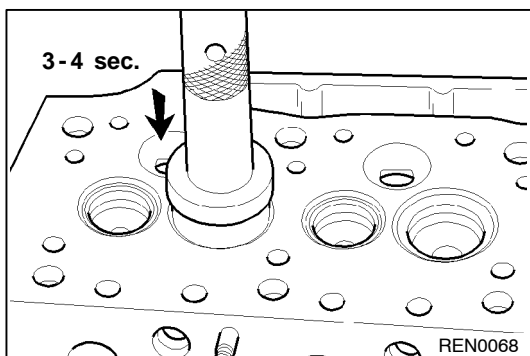

- (4) Install the intake valve seat on valve seat installer MB996022 and exhaust valve seat on valve seat installer MB996023.
- (5) Immerse the valve seats **24, 25** in liquid nitrogen so as to cool them sufficiently.
- (6) Pressing the valve seats **24, 25** with the valve seat installers MB996022 and MB996023 in the bores until they abut in the cylinder head.
- (7) After the valve seats **24, 25** have been installed, the valve seats and the valves **16, 17** must be matched by lapping.

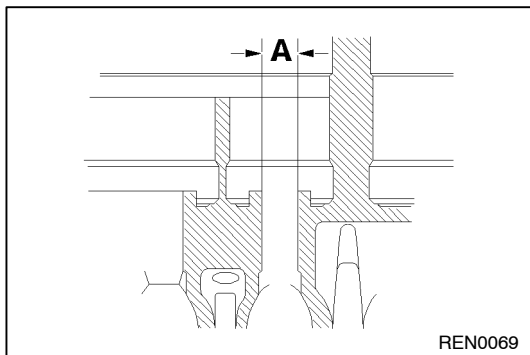

▶◀ VALVE GUIDE INSTALLATION

- (1) Measure the diameter of the bores for the valve guides **22, 23** in the cylinder head **31**. If a measured value does not come within the specified tolerance range, select the oversize valve guide.

Standard value:
Diameter of bore (A): 13 mm

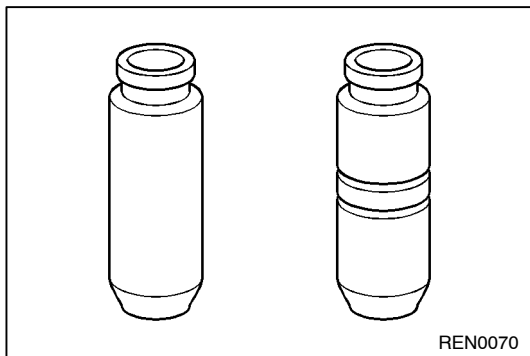

- (2) Ream valve guide bore (dimension A) to the outside diameter of the selected oversize valve guides with reamer MB996016.

Oversize valve guide diameter = 13.3 mm
 (two grooves)

- (3) Place the cylinder head **31** on a flat surface.
- (4) Locate the valve guides **22, 23**, with the taper pointing down, on valve guide installer MB996029.
- (5) Press in the valve guides **22, 23** until the installer abuts the cylinder head **31**.

Caution

- The pressure exerted on the valve guide must be at least 9,000 N. If the pressure is lower, the valve guide must be removed. Ream the valve guide bore in the cylinder head to the next oversize and press in the corresponding valve guide.

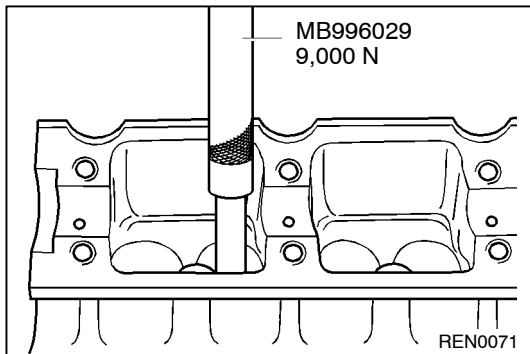

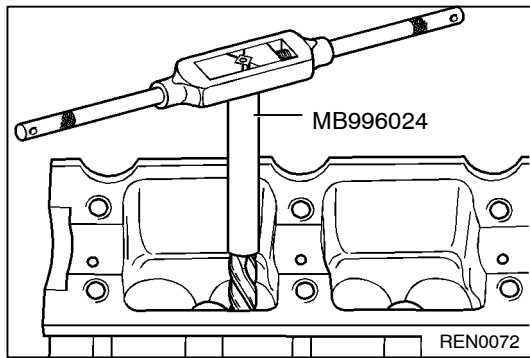

- (6) Clean the valve guide inner bores **22**, **23** with reamer MB996024.

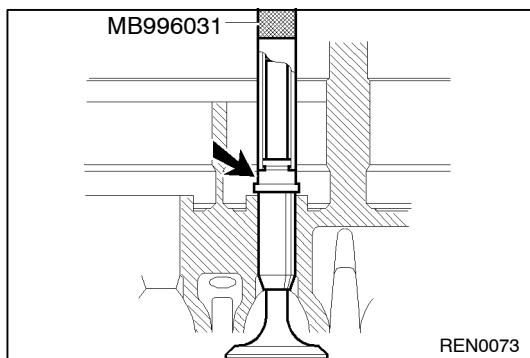

►D◄ VALVE STEM SEAL INSTALLATION

- (1) Lubricate the valve guides **22**, **23** with engine oil. Introduce the valves **16**, **17** through the valve guides. Locate the protective plastic cap over the valve stem.
- (2) Locate the valve stem oil seal **15**. Press in the valve stem oil seal **15** vertically until it abuts the cylinder head **31** with valve stem seal installer MB996031. Remove the protective cap.

Caution

- To avoid damaging the valve stem oil seal, the valves **16**, **17** must not be removed again.

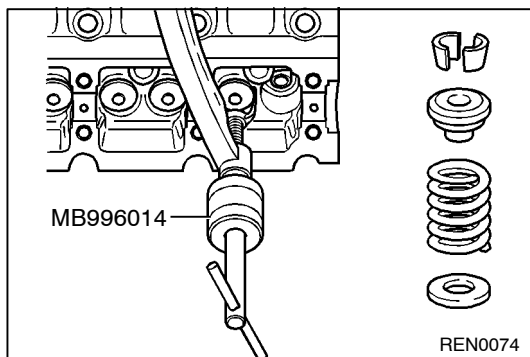

►E◄ RETAINER LOCKS INSTALLATION

- (1) Fit valve spring compressor MB996014 on the cylinder head **31** as shown in the illustration.
- (2) Press down the valve spring retainer **12** and fit the retainer locks **11**.

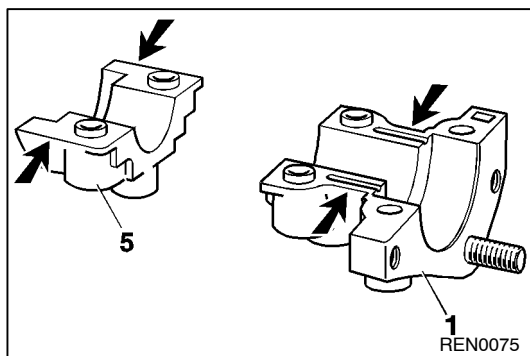

►F◄ CAMSHAFT BEARING CAPS INSTALLATION

- (1) Apply a sealant to the No. 1 and No. 5 bearing caps.

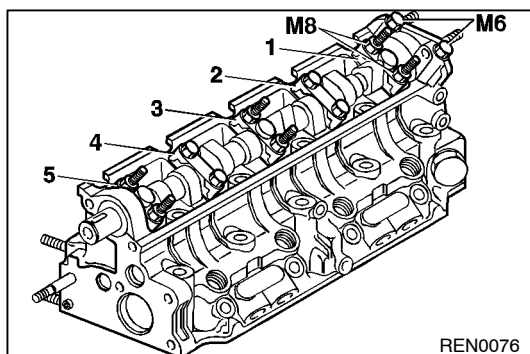

- (2) Fit the camshaft bearing caps in the correct sequence (the caps are numbered). Apply a locking agent to the upper five bolts. Tighten the bolts to the specified torques.

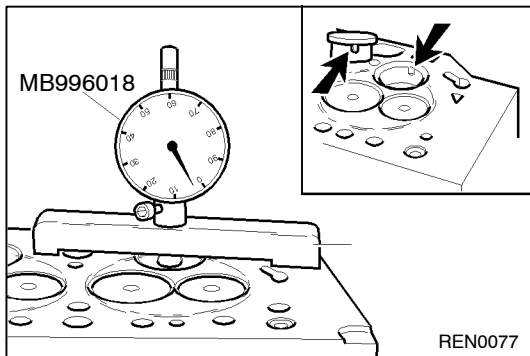

►G◄ SWIRL CHAMBER INSTALLATION

NOTE

First check that the dowel pin is still in the swirl chamber. If the dowel pin is no longer present, a new swirl chamber 26 will have to be fitted.

- (1) Measure the difference in height between the swirl chambers and the cylinder head with slip gauge MB996018 and dial indicator. The difference in height must be between 0.01 and 0.04 mm.
- (2) Fit the glow plugs 18 and connect up the wiring.

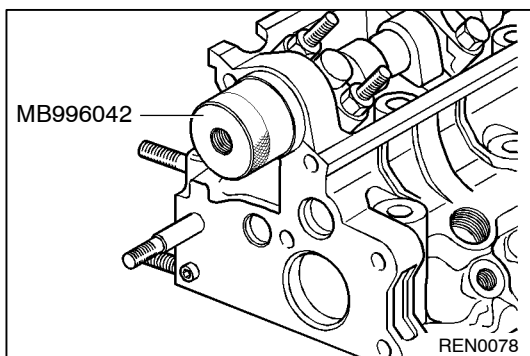

►H◄ CAMSHAFT OIL SEAL INSTALLATION

- (1) Coat the lip of the oil seal with a thin layer of engine oil.
- (2) Locate the oil seal over the camshaft.
- (3) Fit the oil seal with oil seal installer MB996042.

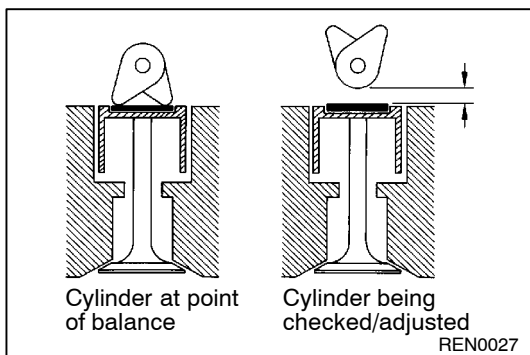

VALVE CLEARANCES ADJUSTMENT

VALVE CLEARANCES CHECK

The valve clearances have to be checked/adjusted in the following sequence:

Cylinder at point of balance	Cylinder being checked/adjusted
1	4
2	3
3	2
4	1

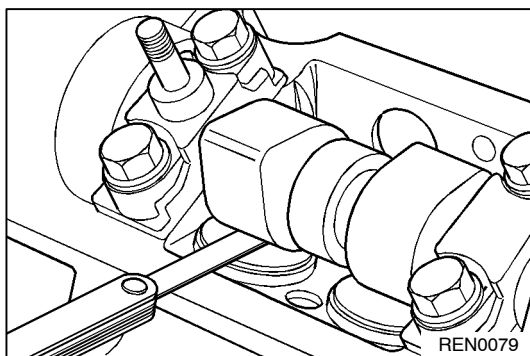

When changing tappet pads the piston must not be at TDC. The crankshaft must be turned on to bring it just past TDC, otherwise the valves may strike the piston when the tappets are depressed.

Cold engine	Checking	Adjusting
Intake valve mm	0.15 - 0.20	0.20
Exhaust valve mm	0.35 - 0.45	0.40

14. VACUUM PUMP

REMOVAL AND INSTALLATION

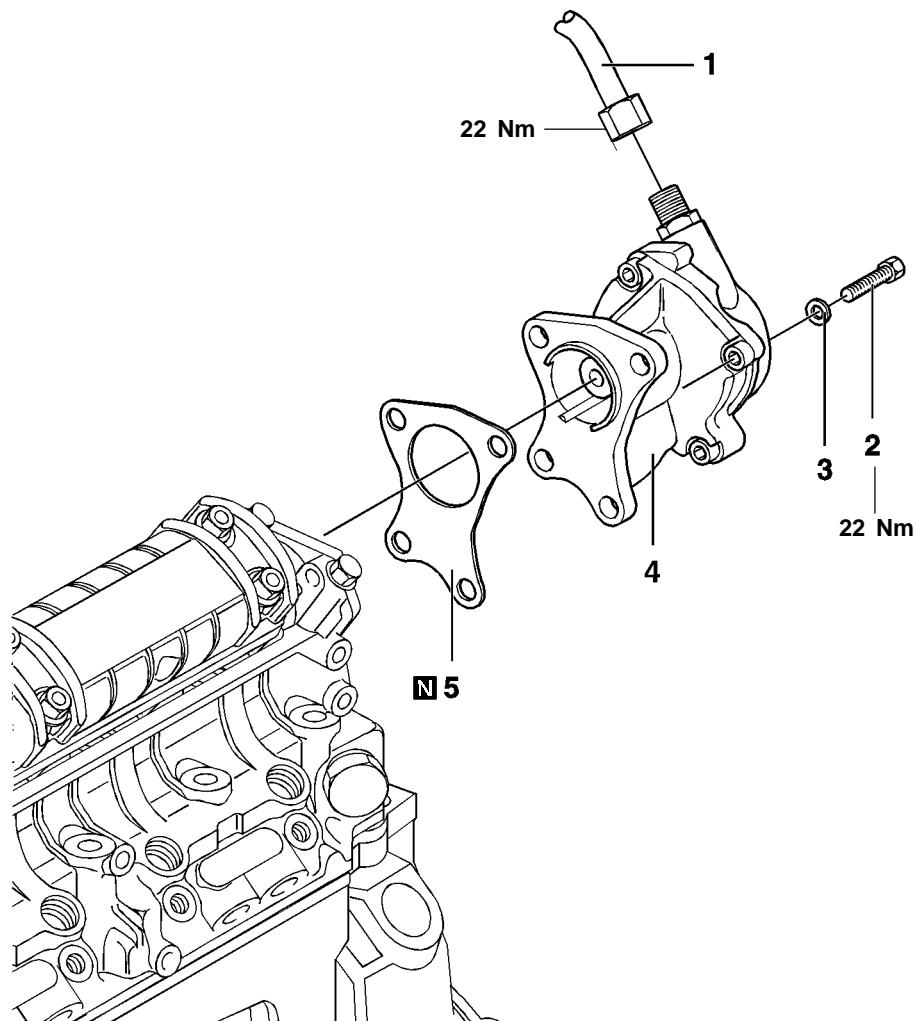

REN0083

Removal steps

1. Vacuum hose
2. Bolt
3. Washer
4. Vacuum pump
5. Gasket

15. OIL COOLER AND OIL FILTER

REMOVAL AND INSTALLATION

 Lubricate all internal parts with engine oil during reassembly.

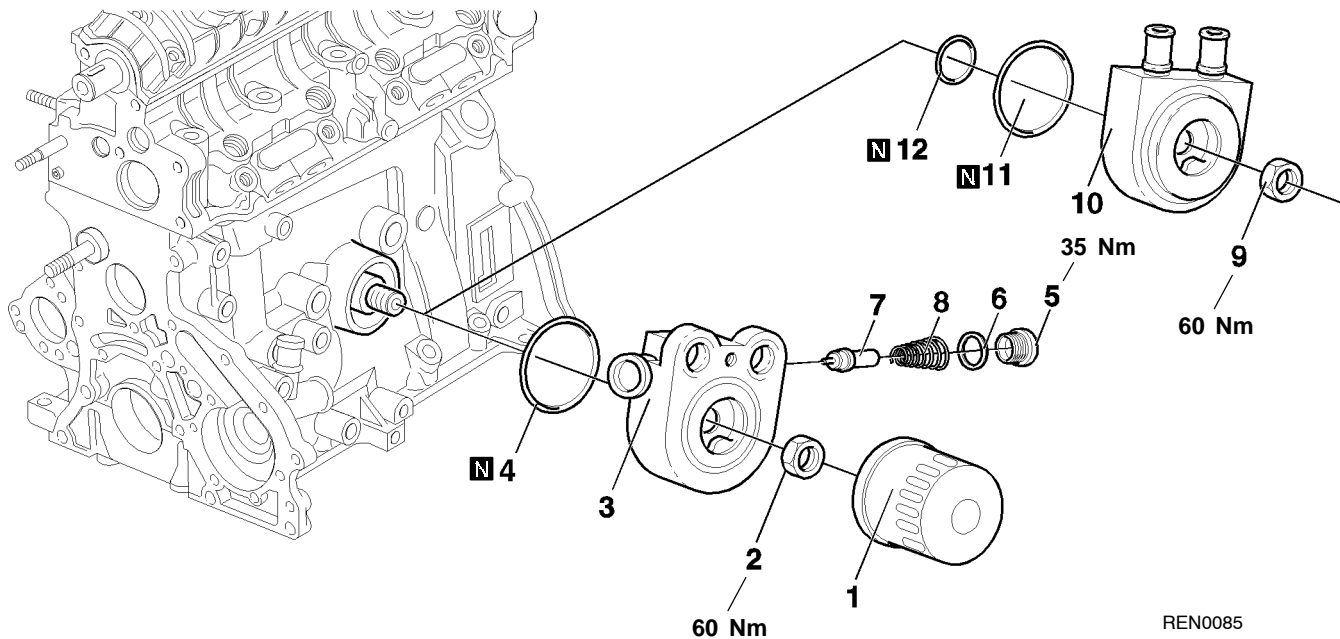

Removal steps



1. Oil filter
2. Nut
3. Thermostat housing
4. O-ring
5. Plug
6. Sealing washer



7. Thermostat
8. Spring
9. Nut
10. Oil cooler
11. O-ring
12. O-ring

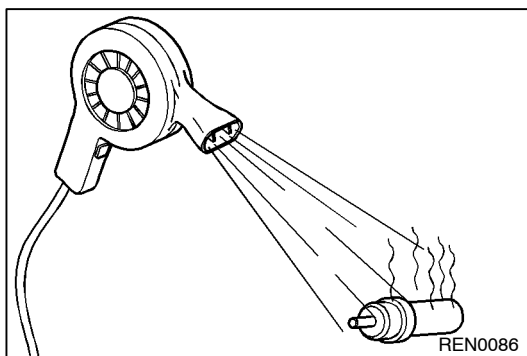

REMOVAL SERVICE POINTS

◀▶ THERMOSTAT REMOVAL

- (1) Remove the socket-head screw and sealing washer.
- (2) Remove the spring together with the thermostat.
Check the operation of the thermostat with the aid of a hair-drier.
Renew the part in question if the specified value is not obtained.

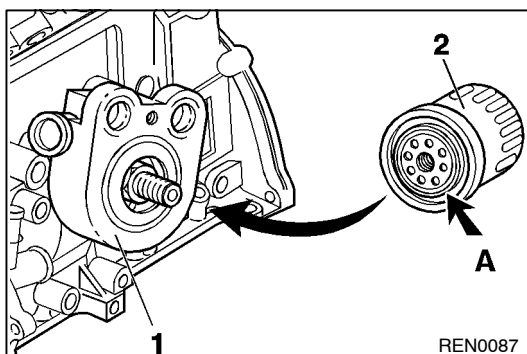

INSTALLATION SERVICE POINTS

▶◀ OIL FILTER INSTALLATION

- (1) Clean that part of the oil cooler 1 which is in contact with the oil filter 2.
- (2) Smear a thin layer of engine oil on the O-ring A of the oil filter 2.

16. OIL PAN, OIL PUMP AND OIL JETS

REMOVAL AND INSTALLATION

 Lubricate all internal parts with engine oil during reassembly.

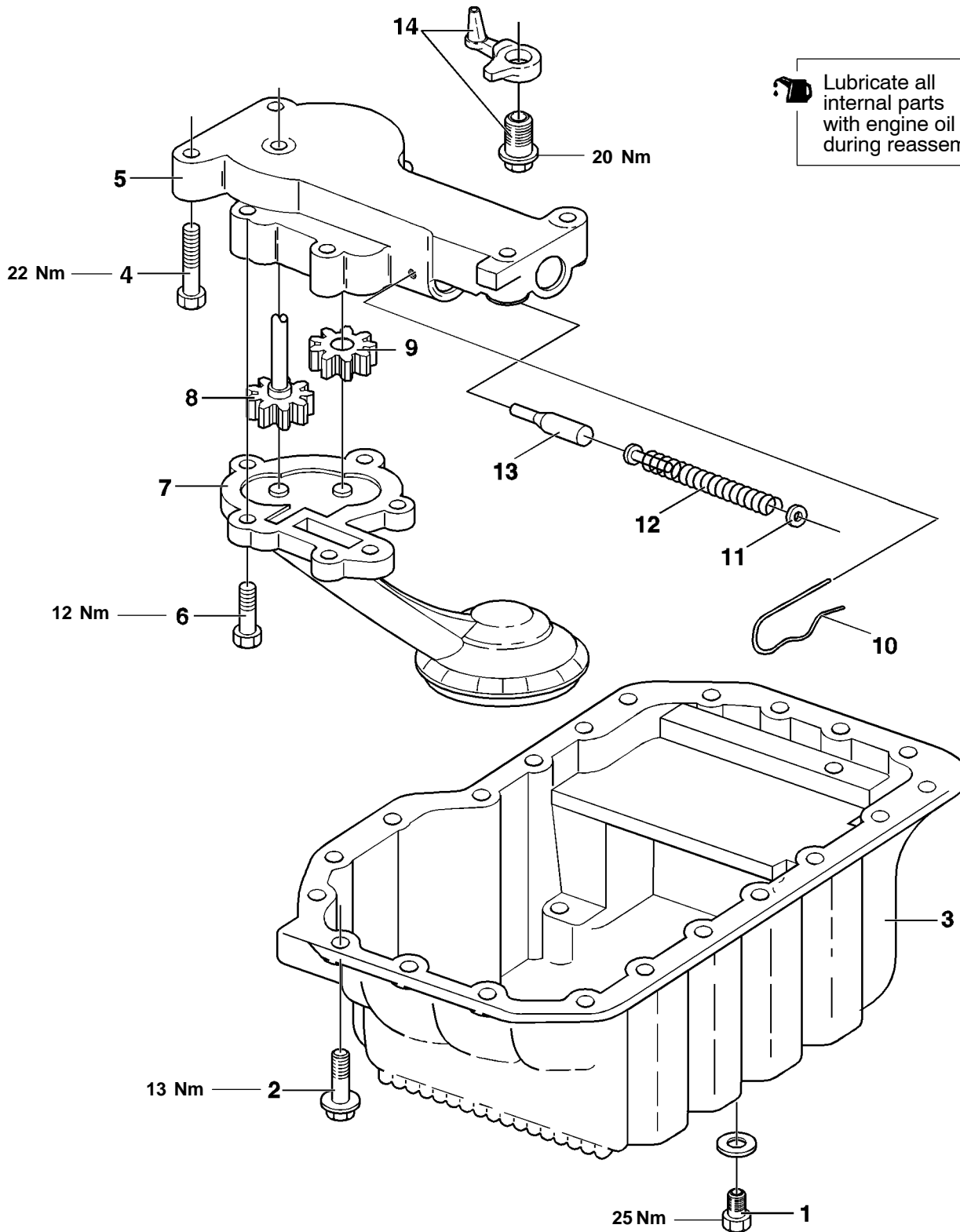

Removal steps



1. Drain plug
2. Bolt
3. Oil pan
4. Bolt
5. Oil pump body
6. Bolt
7. Cover

8. Driven gear
9. Idler gear
10. Spring clip
11. Washer
12. Compression spring
13. Plunger
14. Oil jet

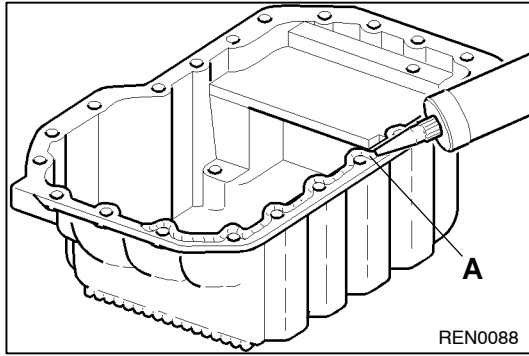

INSTALLATION SERVICE POINTS

▶A◀ OIL PAN INSTALLATION

- (1) When applying sealant, make sure that the cartridge nozzle opening is not larger than 4 mm.
- (2) Apply an even, uninterrupted bead of sealant **A** to the entire circumference of the oil pan flange **3** as shown in the illustration.
- (3) Install the oil pan **3**.

Caution

- Make sure that the surface to which the sealant **A** is applied is free of dirt and other impurities.
- When installing the oil pan, make sure that no sealant **A** is applied to other parts or in the oil passages.

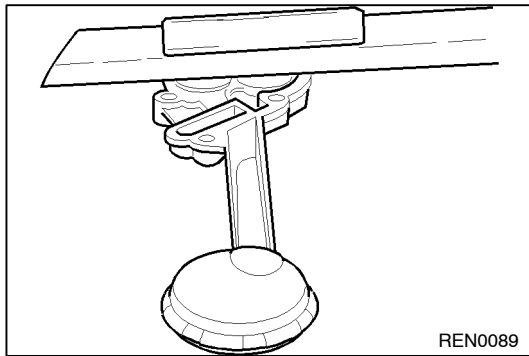

INSPECTION

OIL PUMP

- (1) Check the flatness of the cover with a straight-edge. Surface-sand the cover if necessary.

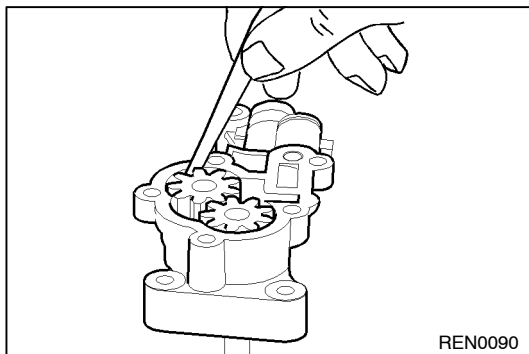

- (2) Clearance between the gears and the pump body
Fit new gears if the clearance is greater than the specified limit value.
If the clearance is still greater than the specified limit value, fit a new oil pump.

17. INTERMEDIATE SHAFT AND INTERMEDIATE SHAFT BEARINGS

 Lubricate all internal parts with engine oil during reassembly.

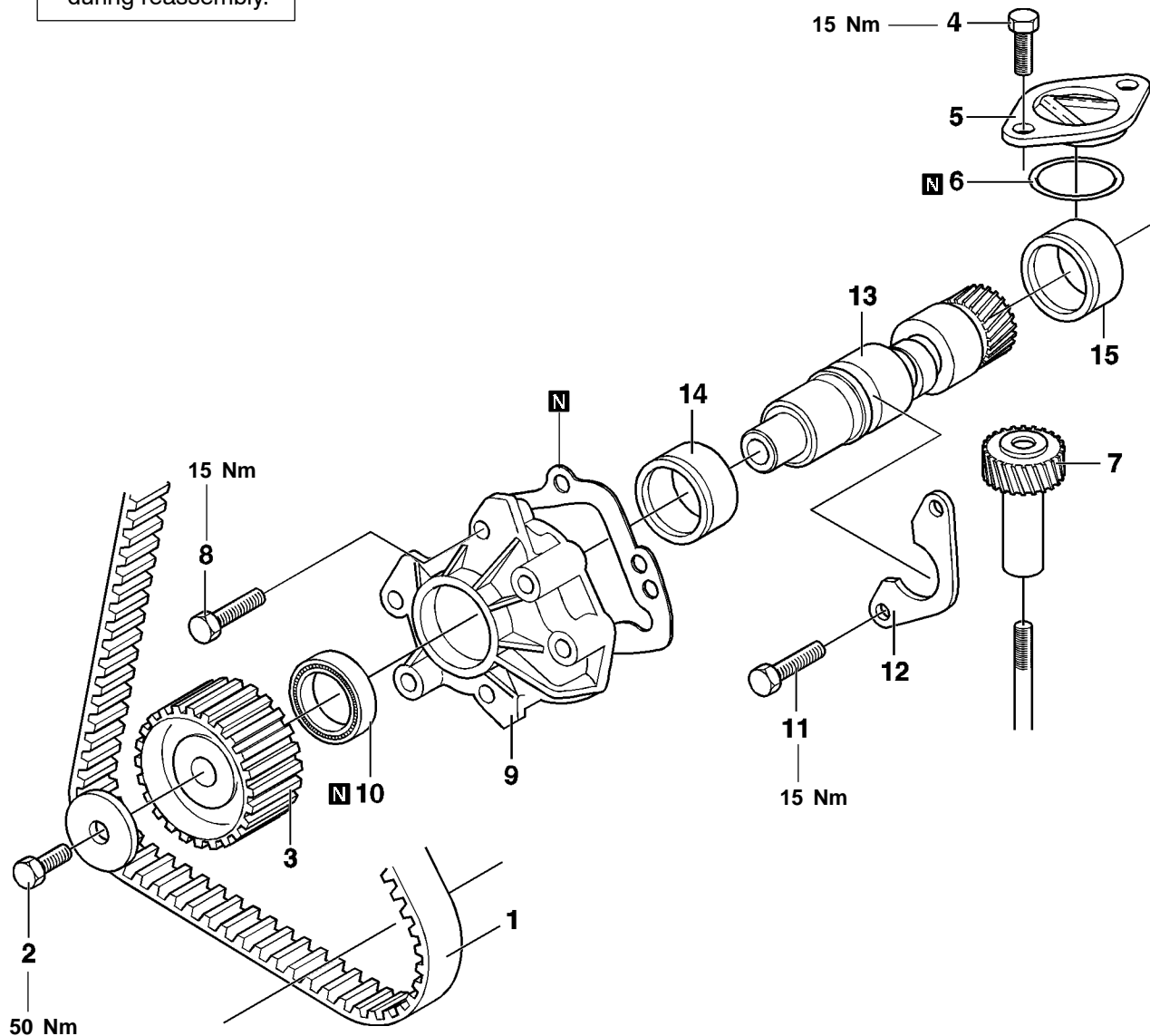

REN0091

Removal steps

- 1. Timing belt
- 2. Bolt
- ◀A▶ ▶E▶ 3. Intermediate shaft sprocket
- 4. Bolt
- 5. Cover
- ◀B▶ 6. O-ring
- 7. Oil pump drive gear
- 8. Bolt

- 9. Cover
- ▶D▶ 10. Oil seal
- 11. Bolt
- ▶C▶ 12. Lockplate
- ▶C▶ 13. Intermediate shaft
- ▶B▶ 14. Outer bearing
- ▶A▶ 15. Inner bearing

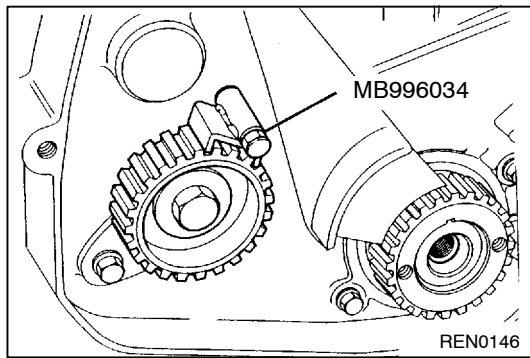

REMOVAL SERVICE POINTS

◀A▶ INTERMEDIATE SHAFT SPROCKET REMOVAL

- (1) Use sprocket stopper MB996034 to hold the sprocket during removal.
- (2) Remove the sprocket and the sprocket key.

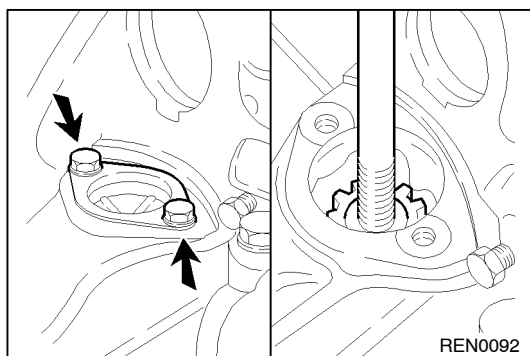

◀B▶ OIL PUMP DRIVE GEAR REMOVAL

- (1) Remove the oil pump drive gear 7 with the aid of an M12 bolt.

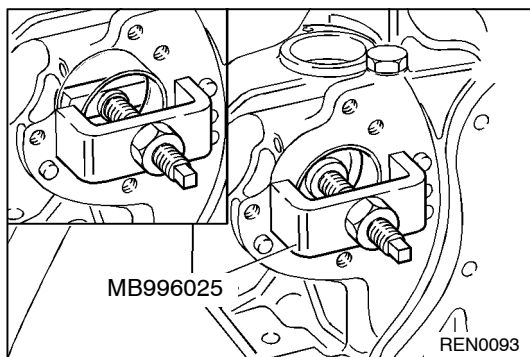

◀C▶ OUTER BEARING REMOVAL

- (1) Remove the outer bearing 14 with bearing puller MB996025.

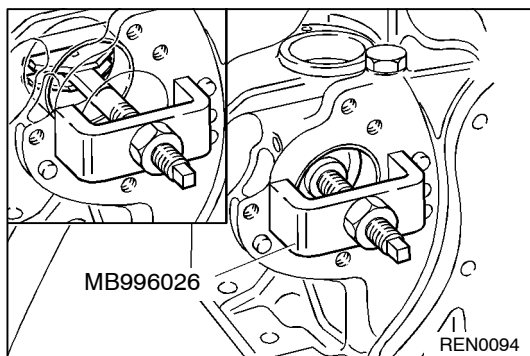

◀D▶ INNER BEARING REMOVAL

- (1) Remove the inner bearing 15 with bearing puller MB996026.

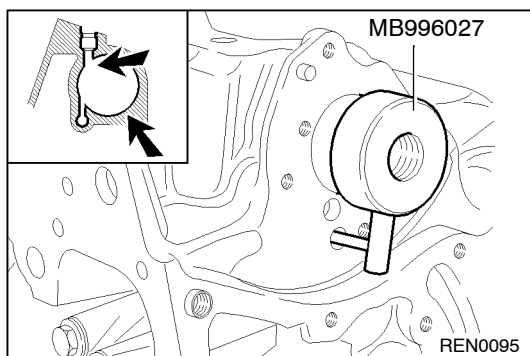

INSTALLATION SERVICE POINTS

▶A◀ INNER BEARING INSTALLATION

- (1) Install the inner bearing with the aid of bearing installer MB996027.
The pin of the installer must engage the oil return passage of the intermediate shaft 13.

NOTE

Position the inner bearing with the opening at the mark on the installer.

- (2) Check with a piece of wire (1.2 mm diameter) that the oil hole is aligned with the drilling in the bearing.

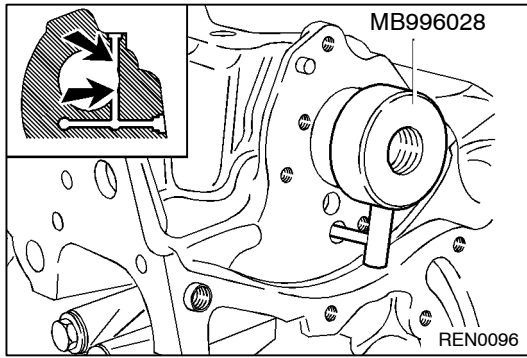

►B◄ OUTER BEARING INSTALLATION

- (1) Install the outer bearing with the aid of bearing installer MB996028.
The pin of the installer must engage the oil return passage of the intermediate shaft **13**.

NOTE

Position the outer bearing with the opening at the mark on the installer.

- (2) Check with a piece of wire (1.2 mm diameter) that the oil hole is aligned with the drilling in the bearing.

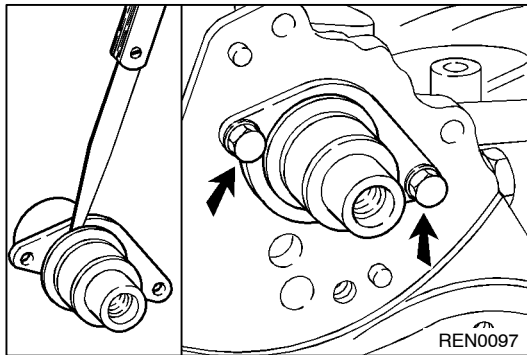

►C◄ INTERMEDIATE SHAFT/LOCK PLATE INSTALLATION

- (1) Measure the clearance between the intermediate shaft and the lock plate.
Replace the part in question if the clearance exceeds the limit value.
- (2) Install the intermediate shaft together with the lock plate.

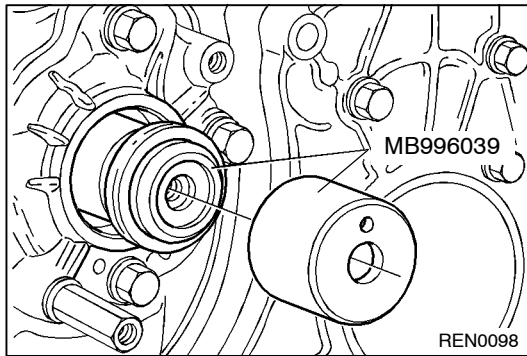

►D◄ INTERMEDIATE SHAFT OIL SEAL INSTALLATION

- (1) Coat the lip of the oil seal with a thin layer of engine oil.
- (2) Locate the oil seal installer guide MB996039 over the intermediate shaft.
- (3) Locate the oil seal over the oil seal installer guide.
- (4) Fit the oil seal with oil seal installer MB996039.

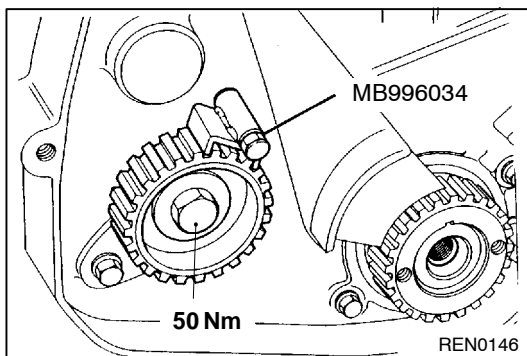

►E◄ INTERMEDIATE SHAFT SPROCKET INSTALLATION

- (1) Use sprocket stopper MB996034 and tighten the retaining bolt to 50 Nm.

18. FUEL INJECTION NOZZLE

REMOVAL AND INSTALLATION

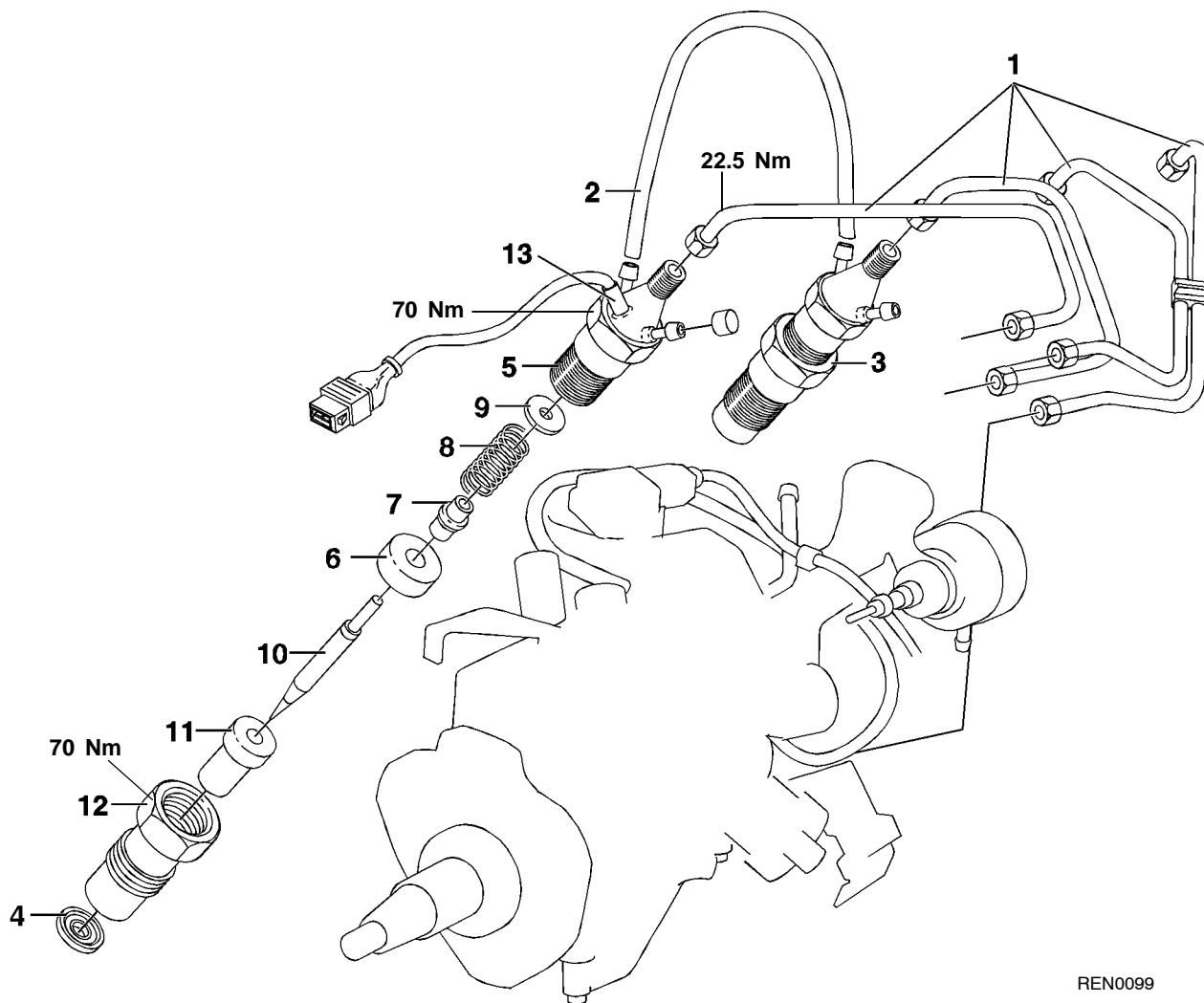

REN0099

Removal steps

- ◀A▶ ▶A▶
1. Injection pipe
 2. Fuel return pipe
 3. Fuel injection nozzle assembly
 4. Heat shield tip
 5. Nozzle body
 6. Washer
 7. Push rod

- ◀B▶
8. Spring
 9. Shim
 10. Needle valve
 11. Nozzle tip
 12. Retaining nut
 13. Nozzle needle lift sensor
(for No. 1 cylinder only)

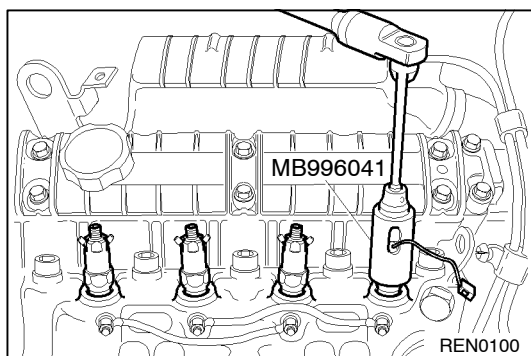

◀A▶ FUEL INJECTION NOZZLE REMOVAL

- (1) Remove the fuel injection nozzle with special socket MB996041.

INSPECTION**FUEL INJECTION NOZZLE**

- (1) Connect the nozzle tester to injection nozzle **3** and carry out the tests described below.

Caution

- Before starting the tests, operate the lever of the nozzle tester two or three times to bleed air from the nozzle.

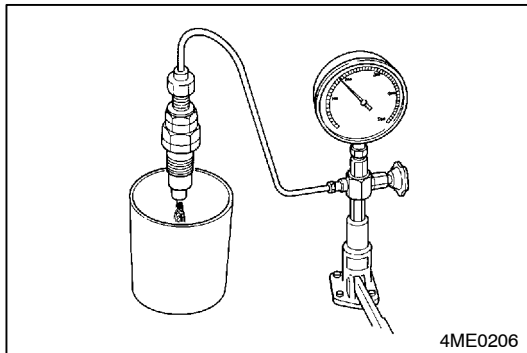
**Valve opening pressure test**

- (1) Slowly push down the nozzle tester lever. The pressure gauge pointer will gradually rise and then deflect suddenly at a certain value. Make a note of the pressure at which the pointer suddenly deflects.
- (2) If this pressure value deviates from the standard value, disassemble the nozzle. Clean and reassemble the nozzle. Then adjust to the specified pressure by fitting a different shim **9**.
- (3) A difference in shim thickness of 0.05 mm changes the opening pressure by 5 kPa. Shims are available in thicknesses from 1.00 to 1.95 mm, increasing by increments of 0.05 mm.
- (4) Fit a new fuel injection nozzle **3** if the pressure value is still incorrect after adjustment.

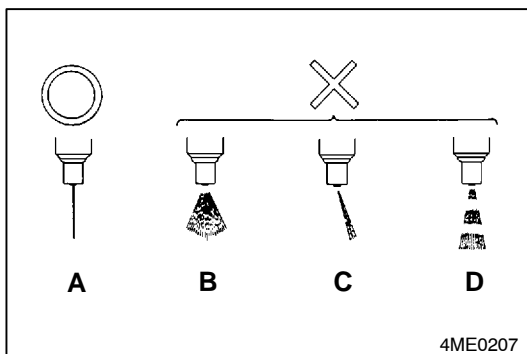
**Spray pattern test**

- (1) Move the nozzle tester lever with a fast short stroke (four to six strokes per second) so that a continuous spray of fuel is obtained from the nozzle.
 - A: The fuel exits the nozzle in a straight thin spray pattern (correct).
 - B: Excessive spray angle (incorrect).
 - C: Spray deflected to one side (incorrect).
 - D: Interrupted spray form (incorrect).
- (2) If necessary, disassemble and clean the injection nozzle and repeat the test. Fit a new injection nozzle if the problem persists.
- (3) Check that the nozzle does not drip after injecting fuel.

Caution

- Do not expose your hands or any other parts of your body to the injection nozzle spray.

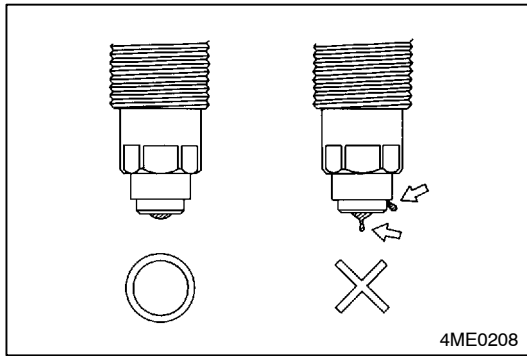

Leakage test

- (1) Increase the pressure to 11 MPa by operating the lever of the nozzle tester. Maintain the pressure for 10 seconds. No fuel must dribble out of the nozzle during this test.
- (2) If dribbling starts within this 10 second period, disassemble and clean the injection nozzle **3** and repeat the test. Fit a new injection nozzle if the problem persists.

REMOVAL SERVICE POINTS

◀A▶ FUEL INJECTION NOZZLE DISASSEMBLY

Caution

- Remove any carbon deposits from the injection nozzle **3** before starting disassembly, assembly and adjustment. Before disassembly, test the fuel injection nozzle for abnormal injection pressure, abnormal spray pattern and leakage. If the fuel injection nozzle is operating correctly, it does not have to be disassembled.

◀B▶ NEEDLE VALVE / NOZZLE TIP REMOVAL

Caution

- Do not touch the sliding surface **A** of the needle valve **10**.
- Make sure that the original combination of needle valve **10** and nozzle tip **11** are reassembled.

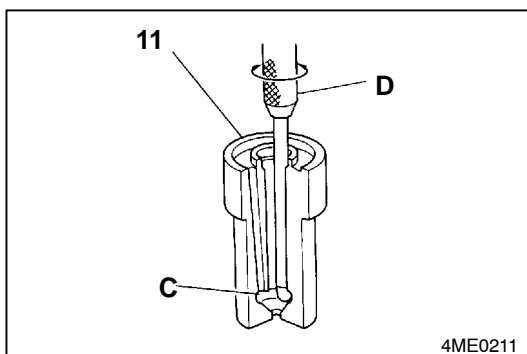
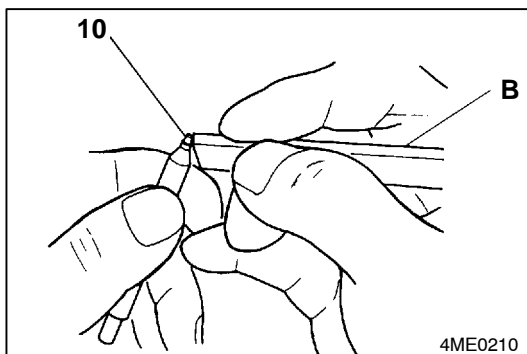
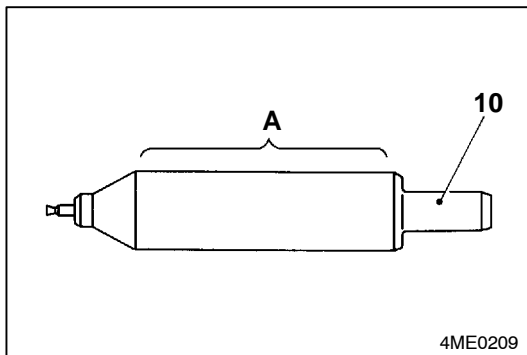

CLEANING

NEEDLE VALVE / NOZZLE TIP

- (1) Wash the removed needle valve **10** and nozzle tip **11** in clean paraffin and remove any carbon deposits with the tool. Proceed as follows:
 - (a) Remove the carbon deposits on the tip of the needle valve **10** with the small cleaning rod **B** (special tool).

Caution

- Do not use a wire brush or other hard metal tools for cleaning.
- (b) Remove the carbon deposits in the oil hole **C** of the nozzle tip **11** with the scraper tool **D**.

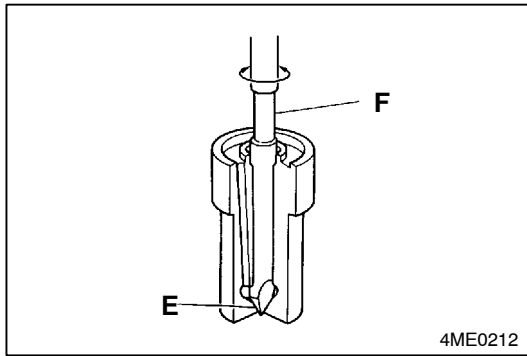

- (c) Clean the seating **E** of the nozzle tip **11** with the special scraper tool **F**.

Caution

- Take care not to damage the seating face.

- (d) Use Fuso carbon deposit cleaning agent to remove encrusted carbon deposits.

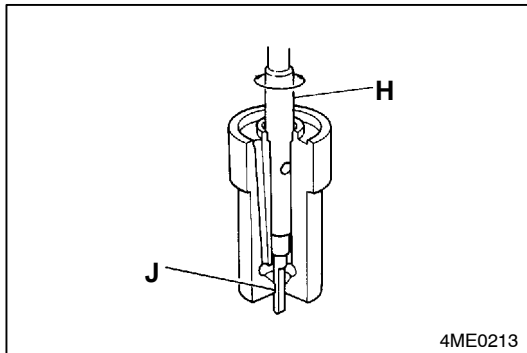

- (e) Remove the carbon deposits in the injection hole of the nozzle tip **11** by rotating the needle cleaner **H** (special tool) in the injection hole **J**.

Diameter of cleaning needle: less than 1.0 mm

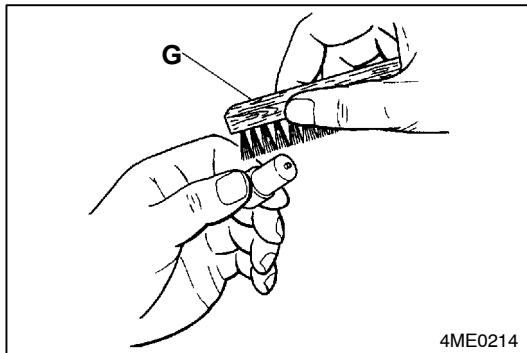

- (f) Remove the carbon deposits on the outside of the nozzle tip **11** with the wire brush **G** (special tool).

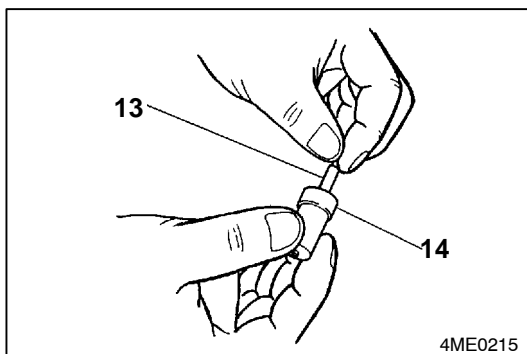

INSPECTION

NEEDLE VALVE/NOZZLE TIP

- (1) Wash the needle valve **10** and nozzle tip **11** in clean paraffin (clean oil) before reassembly.
- (2) Pull out the needle valve **10** about 1/3 of its total length, release it and check whether the needle valve slides back in under the action of gravity. (Repeat this procedure several times and rotate the needle valve slightly each time.)
- (3) If the needle valve **10** does not slide back in, wash it again and repeat the test. If necessary, replace the needle valve **10** and nozzle tip **11** as a set.

INSTALLATION SERVICE POINTS

►A◄ FUEL INJECTION NOZZLE INSTALLATION

Fit new heat shields in the cylinder head with the raised edge facing towards the swirl chamber.

Fit the fuel injection nozzle and tighten them to 70 Nm.

Fit the fuel return hoses on the fuel injection nozzle.

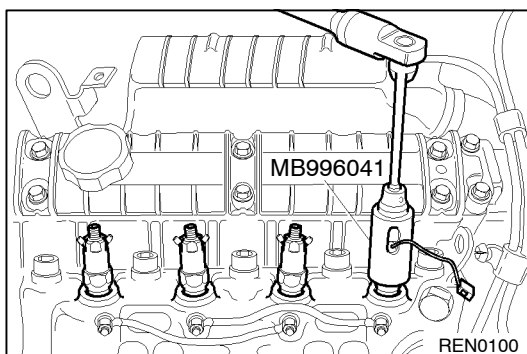

19. FUEL INJECTION PUMP

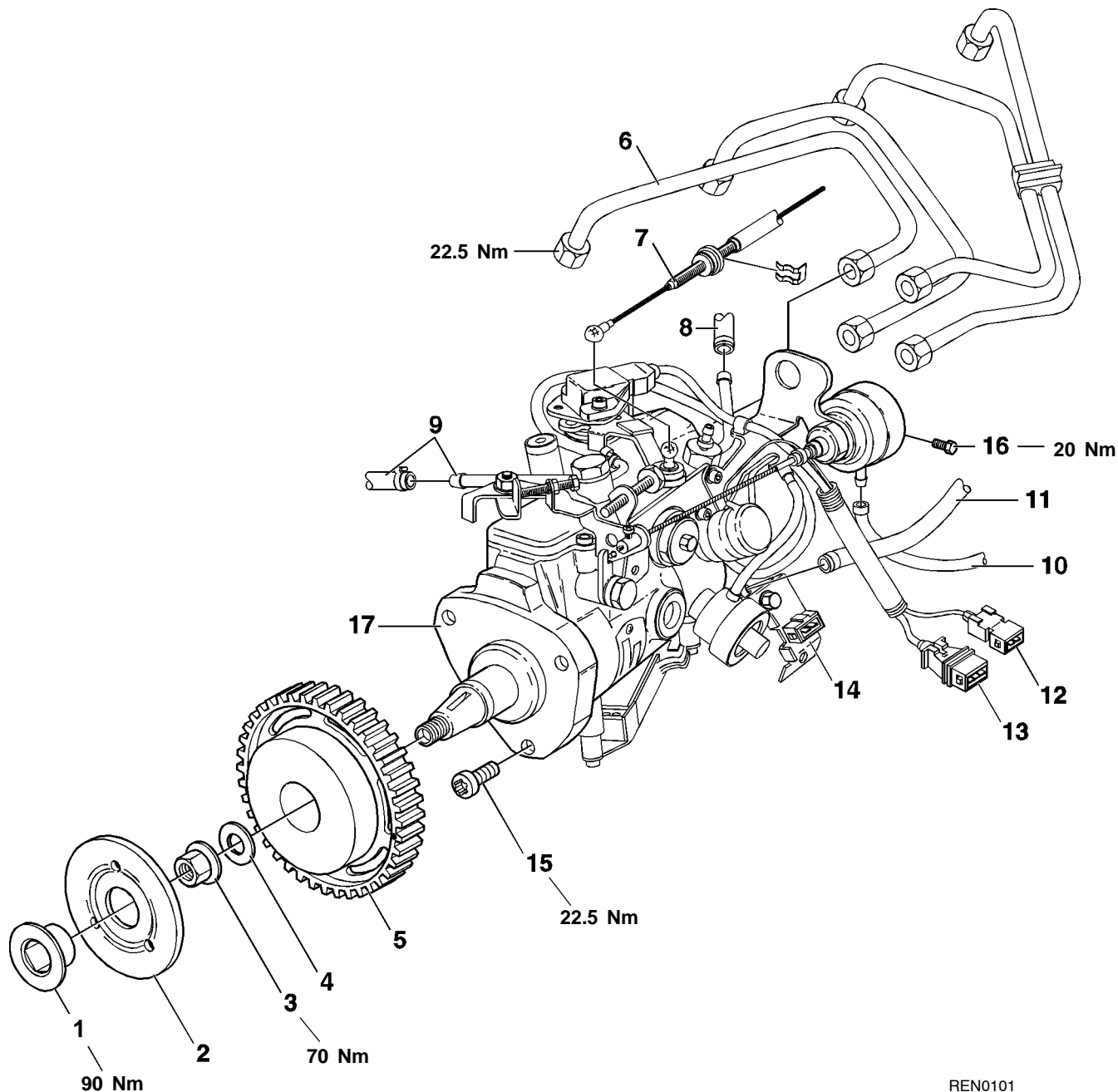

REN0101

Removal steps

1. Screwed sleeve/nut assembly
2. Flange
3. Nut
4. Washer
5. Sprocket
6. Injection pipe
7. Throttle cable
8. Fuel return pipe
9. Fuel supply pipe



10. Vacuum hose
11. Vacuum hose
12. Wiring harness connector
13. Wiring harness connector
14. Wiring harness connector
15. Bolt
16. Bolt
17. Fuel injection pump

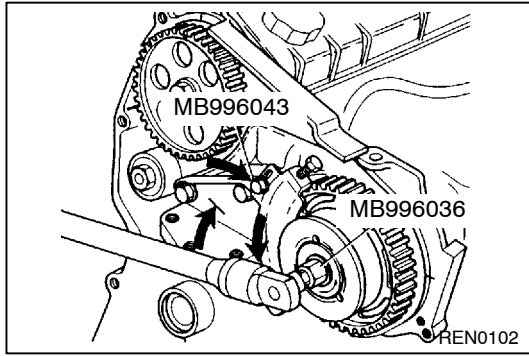

REMOVAL SERVICE POINTS

◀A▶ SPROCKET REMOVAL

- (1) Locate the sprocket stopper MB996043 between the pump bracket and the sprocket. Fasten the tool with the bolts supplied with the set.
- (2) Remove the screwed sleeve and nut assembly with hexagon socket spanner MB996036 (release by turning clockwise).
- (3) Remove the nut.
- (4) Pull the sprocket off the shaft with a gear puller. Remove the locking tool.

◀B▶ FUEL INJECTION PUMP REMOVAL

- (1) Remove the injection pipes.
- (2) Remove the three bolts 15.
- (3) Remove the two bolts 16.

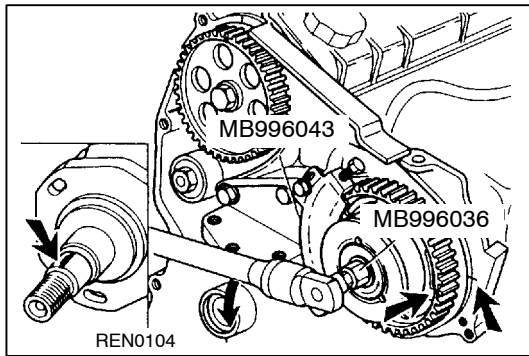
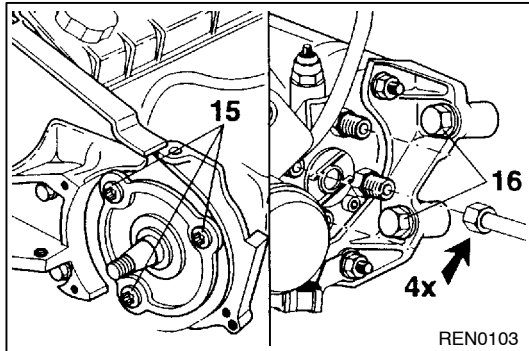

INSTALLATION SERVICE POINTS

▶A◀ SPROCKET INSTALLATION

- (1) Locate the sprocket with the key on the fuel injection pump shaft. Align the sprocket with the mark opposite the pump bracket.
- (2) Locate the sprocket stopper MB996043 between the pump bracket and the sprocket. Fasten the tool with the bolt supplied with the set.
- (3) Fit and tighten the nut to the specified torque.
- (4) Locate the flange with the screwed sleeve and nut assembly and tighten to the specified torque with hexagon socket spanner MB996036.

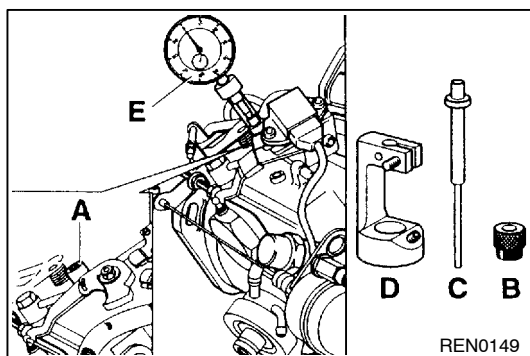
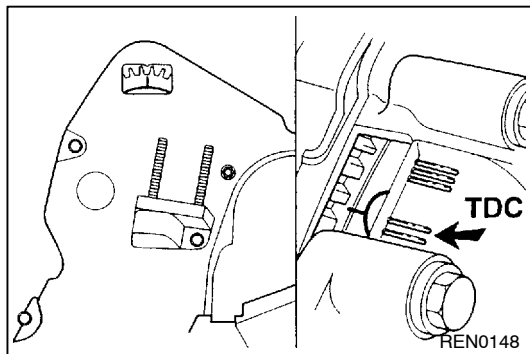

FUEL INJECTION TIMING CHECK

MEASURING TOOL INSTALLATION

- (1) Turn the crankshaft clockwise so that the piston of No. 1 cylinder (flywheel end) is at TDC, with the following marks in line with each other:
 - flywheel/clutch housing
 - timing belt cover/camshaft sprocket.
- (2) Turn the crankshaft (clockwise) 1 3/4 revolutions.
- (3) Remove the plug A.
- (4) Fit measuring device adaptor MB996030:
 - Locate the guide bush B in the pump.
 - Slide the measuring pin C, which is part of the measuring tool, into the guideway of the pump.
 - Locate and secure the holder D.
- (5) Position the clock gauge E and make sure that the plunger is pressed in at least 0.2 mm. Secure the clock gauge and set it at zero.

NOTE

When turning the engine with the gauge installed you might damage the clock gauge. The measuring pin and guide bush can only be supplied and used as a set.

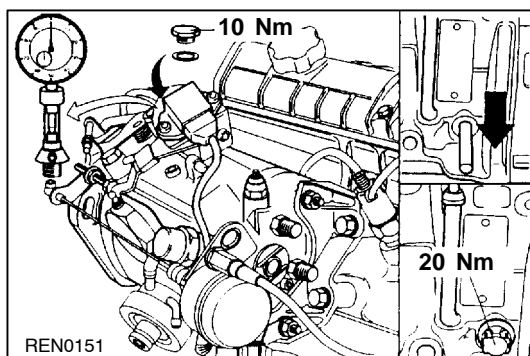
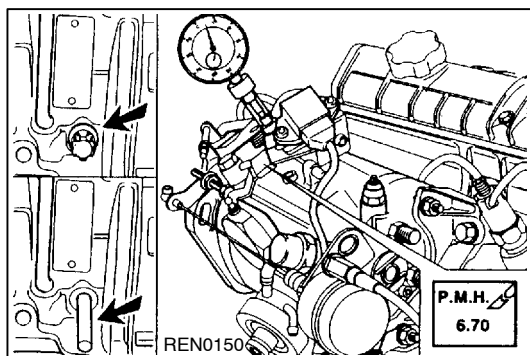

CHECKING THE INJECTION TIMING

- (1) Turn the crankshaft **exactly** to TDC (clockwise). To achieve this:
 - Insert an 8 mm diameter locking pin in the hole of torxbolt.
 - Apply pressure just before TDC on this pin until it engages the recess in the crankshaft.
- (2) Read off the value on the clock gauge. This value should not differ more the 0.02 mm as the set value shown on the pump control arm. If the value is not obtained, the pump has to be adjusted.

MEASURING TOOL REMOVAL

- (1) Remove measuring device adaptor MB996030 with the clock gauge. Fit the plug with a new O-ring. Tighten the plug to the 10 Nm. Remove the locking pin and fit the torxbolt with a new sealing washer. Tighten the plug to 20 Nm.

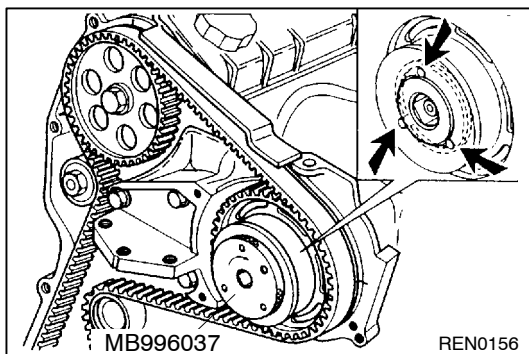
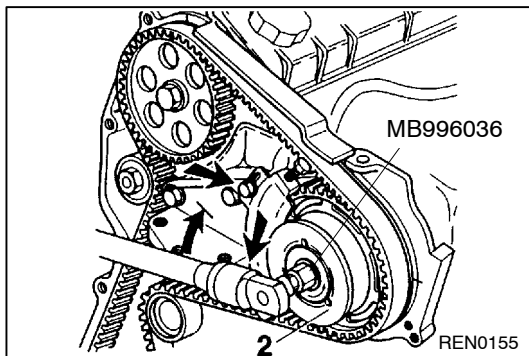
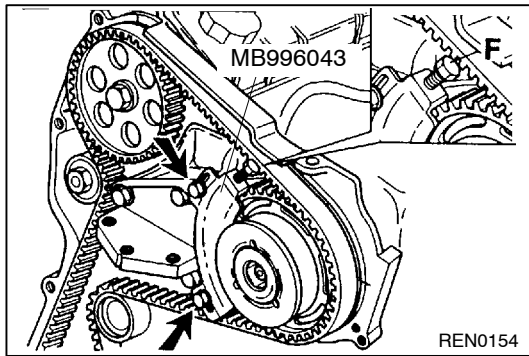
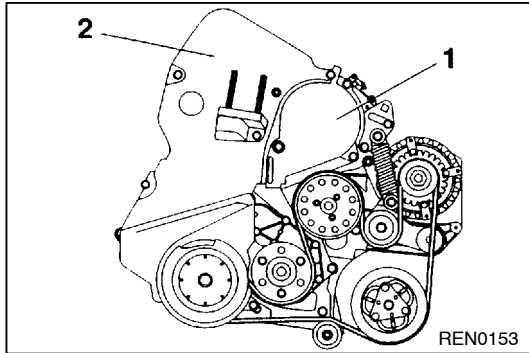
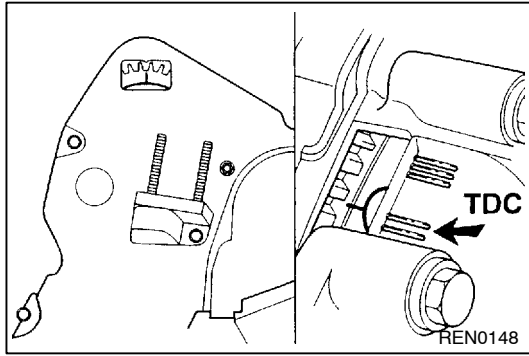

FUEL INJECTION PUMP ADJUSTMENT

MEASURING TOOL INSTALLATION

- (1) Turn the crankshaft clockwise so that the piston of No. 1 cylinder (flywheel end) is at TDC, with the following marks in line with each other:
 - flywheel/clutch housing
 - timing belt cover/camshaft sprocket.

- (2) Remove cover 1 and the bolts of cover 2.

- (3) Locate sprocket stopper MB996043 between the pump bracket and the sprocket. Secure the tool with the two bolts supplied with the set. Bolt F is not needed now.

ADJUSTMENT OF THE INJECTION TIMING

- (1) Insert Hexagon socket spanner MB996036 in the nut assembly. Loosen nut assembly (approx. 1/4 of turn **clockwise**) until it is possible to move the flange 2.
- (2) Remove sprocket stopper MB996043.

- (3) Fit sprocket adaptor MB996037 in the three holes of the flange. Turn the tool with the flange until the jaws of the tool engage the three internal recesses of the sprocket.
- (4) Turn the tool by hand with the flange **clockwise** until the stop. Remove sprocket adaptor MB996037.

- (5) Turn the crankshaft (clockwise) 1 3/4 revolutions.
- (6) Remove the plug **A**.
- (7) Fit measuring device adaptor MB996030.
 - Locate the guide bush **B** in the pump.
 - Slide the measuring pin **C**, which is part of the measuring tool, into the guideway of the pump.
 - Locate and secure the holder **D**.

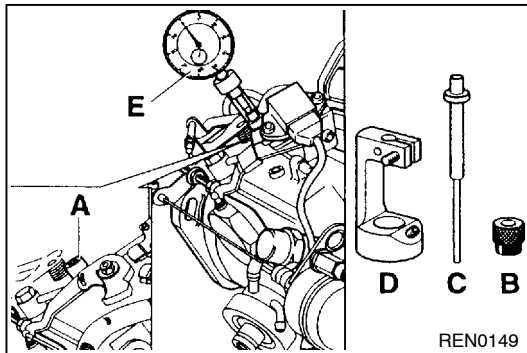

- (8) Position the clock gauge **E** and make sure that the plunger is pressed in at least 0.2 mm. Secure the clock gauge and set it at zero.

Caution

- **When turning the engine with the gauge installed you might damage the clock gauge.**

NOTE

The measuring pin and guide bush can only be supplied and used as a set.

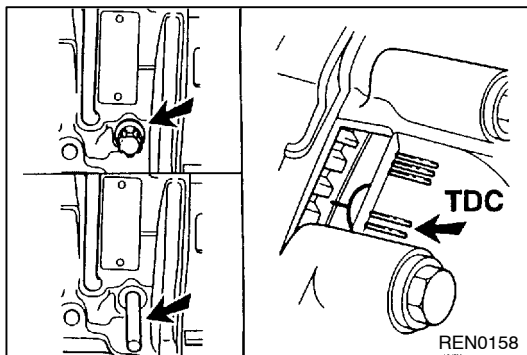

- (9) Turn the crankshaft **exactly** to TDC (clockwise). To achieve this:
 - Insert an 8 mm diameter locking pin in the hole of torxbolt.
 - Apply pressure just before TDC on this pin until it engages the recess in the crankshaft.

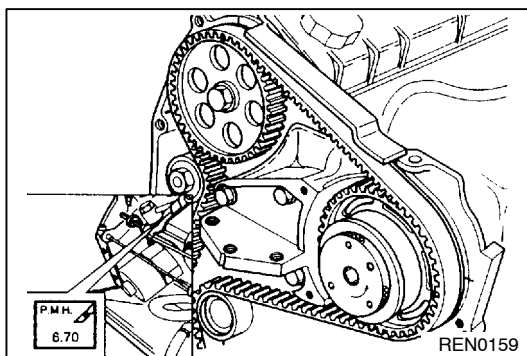

- (10) Now turn the flange with sprocket adaptor MB996037 counterclockwise until the adjustment value is obtained as shown on the pump ± 0.02 mm.

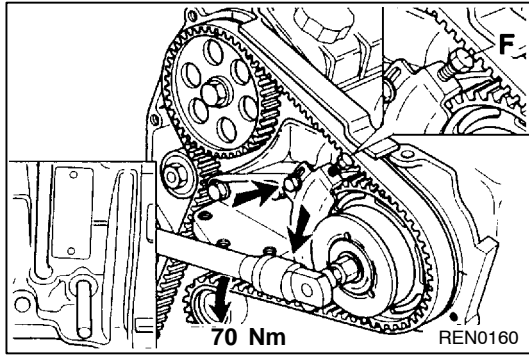

- (11) Locate sprocket stopper MB996043.
Fix the bracket with the two bolts supplied with the set.
Secure the bracket with bolt F so that it is free from play.

Caution

The pump sprocket must not be displaced (the pointer of the micrometer must not move).

- (12) Insert Hexagon socket spanner MB996036 in the nut assembly and tighten the assembly steadily (turning counter-clockwise) to 70 Nm.
(13) Remove sprocket stopper MB996043, the locking pin and clock gauge.
Check the injection timing.

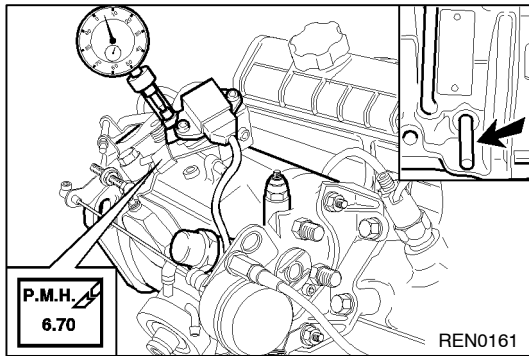

CHECKING THE INJECTION TIMING

- (1) Turn the crankshaft 1 3/4 revolutions clockwise.
- (2) Position the clock gauge and make sure that the plunger is pressed in at least 0.2 mm.
Secure the clock gauge and set it at zero.
- (3) Turn the crankshaft **exactly** to TDC (clockwise).
To achieve this:
 - Insert an 8 mm diameter locking pin in the hole of torxbolt.
 - Apply pressure just before TDC on this pin until it engages the recess in the crankshaft.
- (4) Read off the value on the clock gauge.
This value should not differ more than 0.02 mm as the set value shown on the pump control arm.
If the value is not obtained, the pump has to be adjusted.

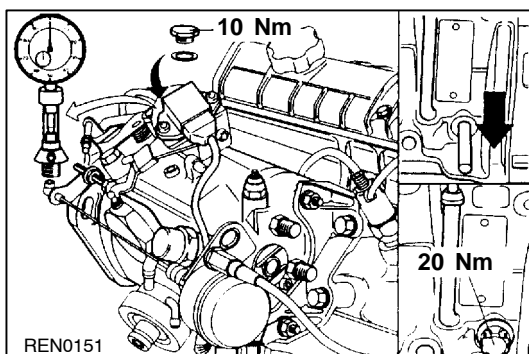

MEASURING TOOL REMOVAL

- (1) Remove measuring device adaptor MB996030 with the clock gauge. Fit the plug with a new O-ring.
Tighten the plug to the 10 Nm.
Remove the locking pin and fit the torxbolt with a new sealing washer.
Tighten the plug to 20 Nm.

20. PISTONS AND CONNECTING RODS

REMOVAL AND INSTALLATION



Lubricate all internal parts with engine oil during reassembly.

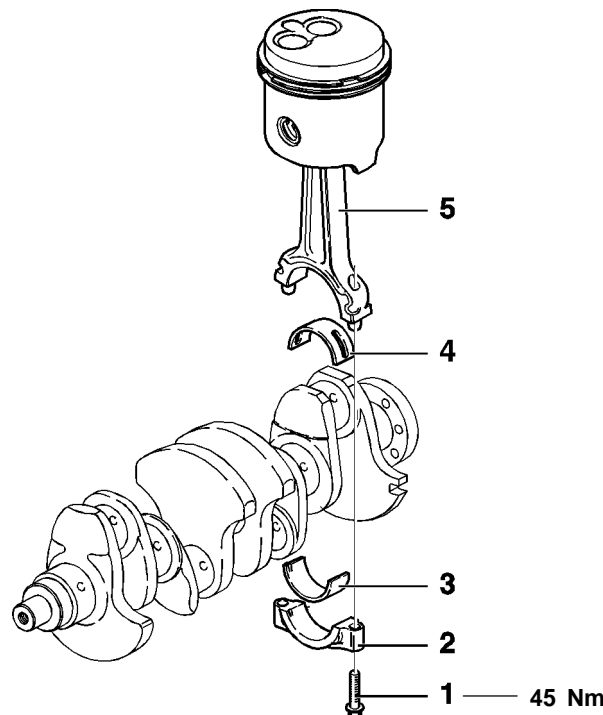

REN0110

Removal steps

1. Bolt
2. Connecting rod cap
- ▶A◀ 3. Connecting rod lower bearing (big-end bearing)

- ▶A◀ 4. Connecting rod upper bearing (big-end bearing)
- ▶B◀ 5. Piston and connecting rod assembly

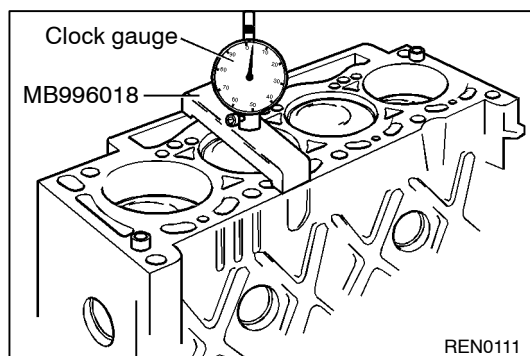

INSPECTION

PISTON AND CONNECTING ROD

Piston height above cylinder block

Caution

- Always check the projecting height of the pistons above the cylinder block. This has a direct influence on engine performance.

- (1) Turn each piston to TDC.
- (2) Check the projecting height of the piston at each cylinder.
- (3) If the average deviates from the standard value, measure the clearance at each piston and connecting rod and the crankshaft.

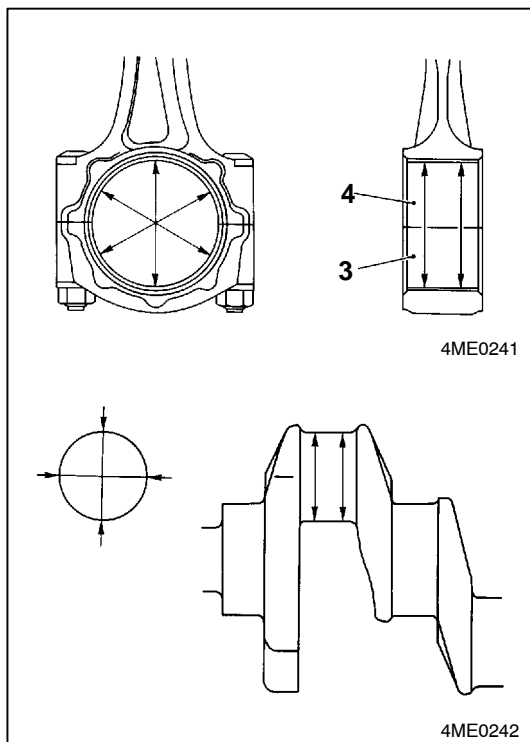

CONNECTING ROD BEARINGS

Caution

- Do not fit old connecting rod bearings 3, 4 if they are badly worn.
- If any one of the connecting rod bearings 3, 4 is defective, the bearings should be replaced as a set.

Clearance between connecting rod and crankshaft

- (1) Replace the part in question if the clearance exceeds the limit value.

PISTON/CONNECTING ROD AND CYLINDER BLOCK

- (1) Measure the cylinder bores.
 Measure four times at 45° intervals and at right-angles to the gasket face, just under the top piston ring travel limit.
 Add the results of these measurements together and divide the total by eight.
 Measure once just above the lower travel limit.
 Divide this value by two.
 Add the values together; this is the cylinder diameter.

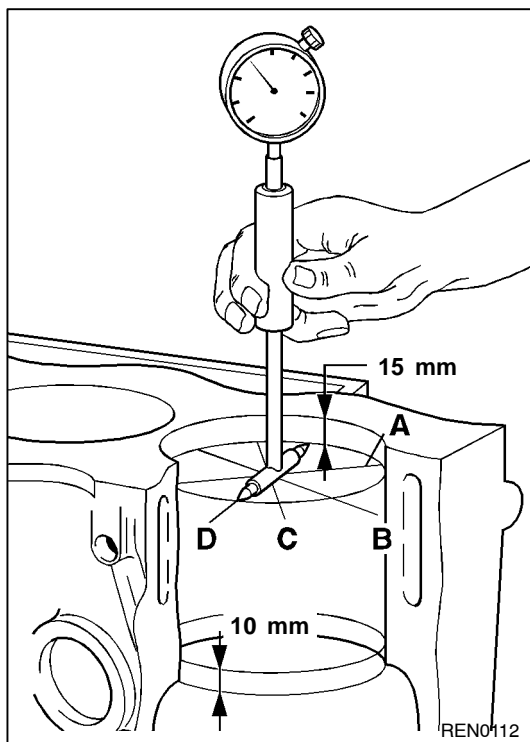

INSTALLATION SERVICE POINTS

▶◀ CONNECTING ROD BEARING INSTALLATION

- (1) Lubricate the bearings with engine oil.

Caution

- Make sure that no engine oil runs in between the bearing, connecting rod and bearing cap.

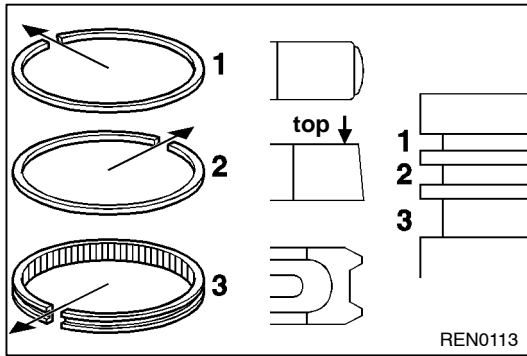

►B◄ PISTON AND CONNECTING ROD INSTALLATION

Caution

- Ensure that the piston ring gaps A are correctly positioned.
- Take care not to damage the piston crown (combustion chamber) B.
- Take care not to strike the connecting rod against the oil jet.

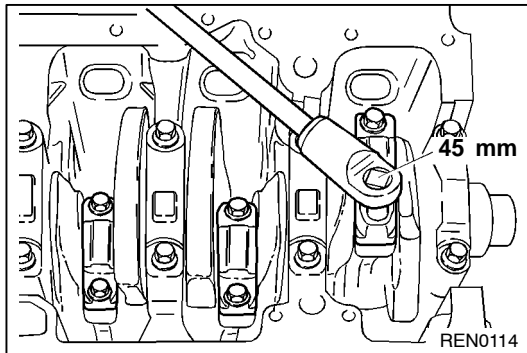

- (1) Lightly coat the big-end journal, cylinder wall and piston with engine oil.
- (2) Fit the connecting rod with the mark facing towards the intermediate shaft side.
- (3) Fit the connecting rod cap with the mark facing towards the intermediate shaft side.
- (4) Fit **new bolts** and tighten them to the specified torque.

NOTE

Check that the crankshaft rotates smoothly.

21. PISTONS AND PISTON PINS

REMOVAL AND INSTALLATION

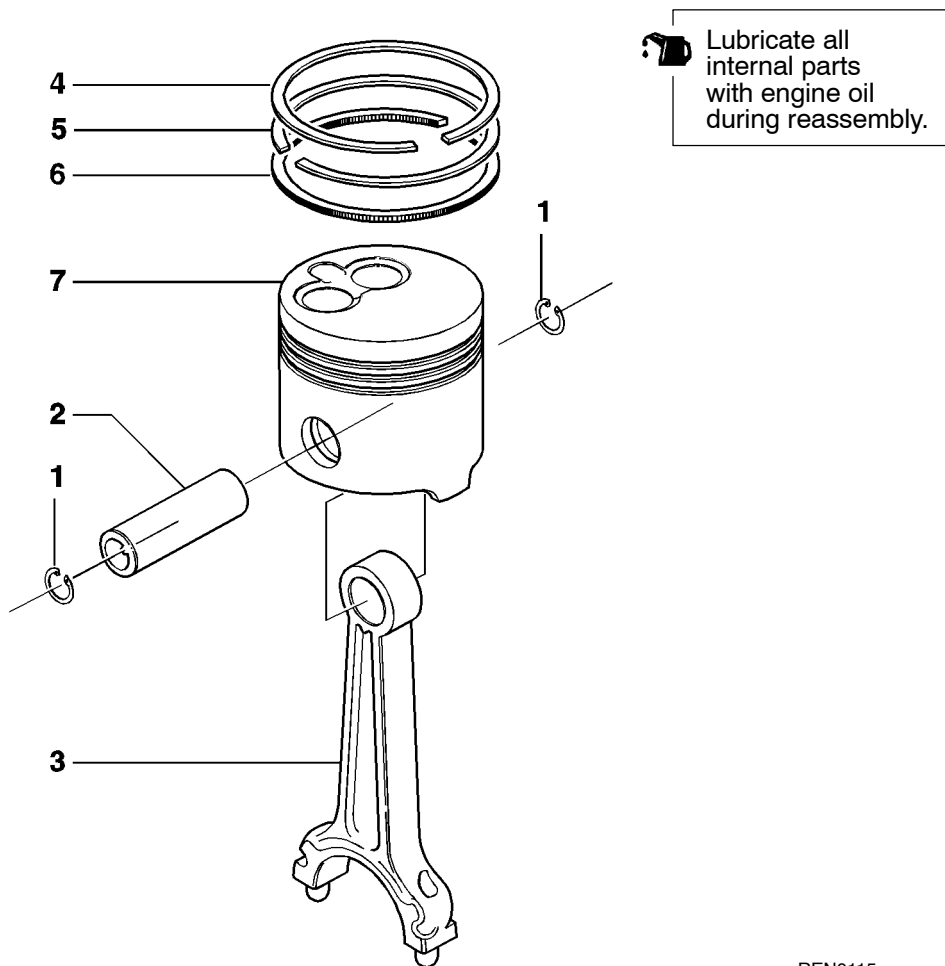

REN0115

Removal steps

- | | | |
|-----|-----|----------------------|
| ◀A▶ | ▶B◀ | 1. Circlip |
| ◀B▶ | ▶A◀ | 2. Piston pin |
| ◀B▶ | ▶A◀ | 3. Connecting rod |
| ◀B▶ | ▶A◀ | 4. Piston ring No. 1 |
| ◀B▶ | ▶A◀ | 5. Piston ring No. 2 |
| ◀B▶ | ▶A◀ | 6. Oil ring |
| | | 7. Piston |

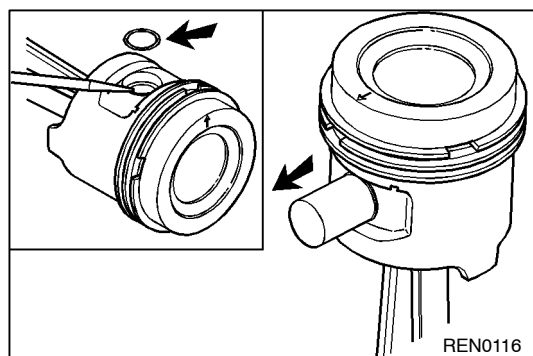

REMOVAL SERVICE POINTS

◀A▶ PISTON PIN REMOVAL

- (1) Remove the circlips.
- (2) Remove the piston pin 2.

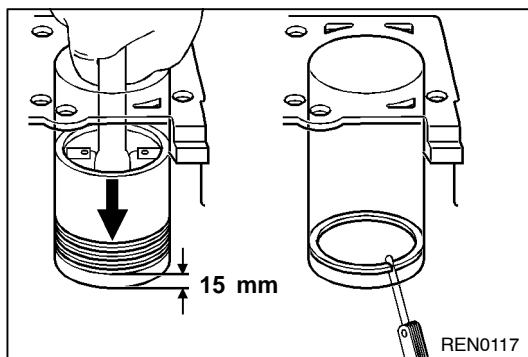
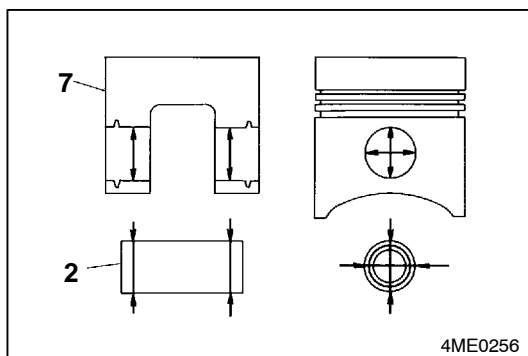
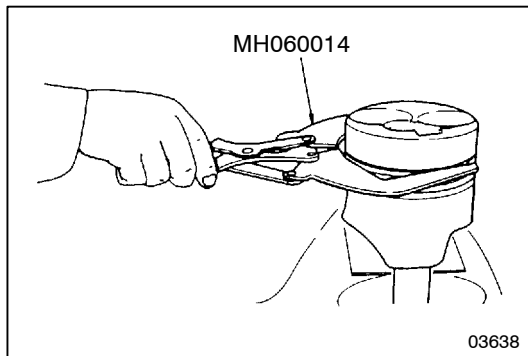

◀B▶ PISTON RING REMOVAL

INSPECTION

PISTON PIN/CONNECTING ROD/PISTON

- (1) Measure the clearance between the piston pin 2 and the piston 7. Replace the part in question if the clearance exceeds the limit value.

PISTON RING GAP

- (1) Insert the piston rings 4, 5, 6 in the cylinder bore of the cylinder block with the aid of the piston 7.
- (2) Hold the piston rings 4, 5, 6 in this position and measure the ring gap with a feeler gauge. Fit new piston rings if the measured value exceeds the limit value.

Caution

- Use the piston 7 so that the piston rings 4, 5, 6 are aligned in the cylinder bore at right-angles to the wall.
- The piston rings 4, 5, 6 must be located in the lower part of the cylinder bore which is subjected to less wear.
- Replace the piston rings 4, 5, 6 as a set.

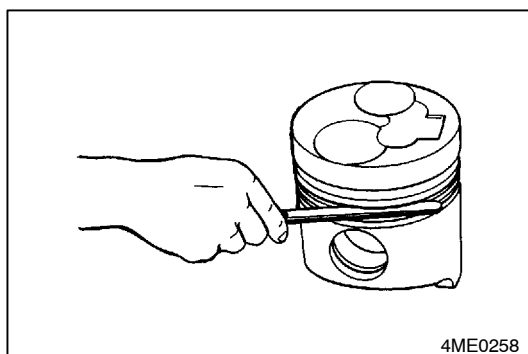

CLEARANCE BETWEEN PISTON RING AND PISTON RING GROOVE

- (1) Replace the part in question if the clearance exceeds the limit value.

Caution

- Always use new piston rings for measuring.
- Remove all traces of carbon deposits from the piston ring grooves in the piston 7 before measuring. Measure the lateral clearance around the entire circumference of the piston ring groove.
- The piston rings must be replaced as a set.

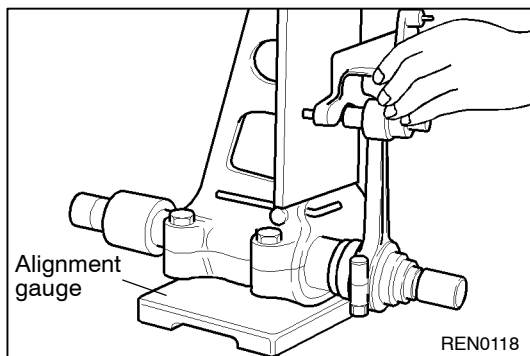

CURVATURE AND TWIST OF CONNECTING ROD

- (1) Measure the curvature and the twist of the connecting rod **3**.

Replace the connecting rod if the limit values are exceeded.

Caution

- Installed connecting rod **3**, with upper and lower connecting rod bearings in place, in the connecting rod alignment tool.
- Tighten the connecting rod cap in accordance with the specified procedure.

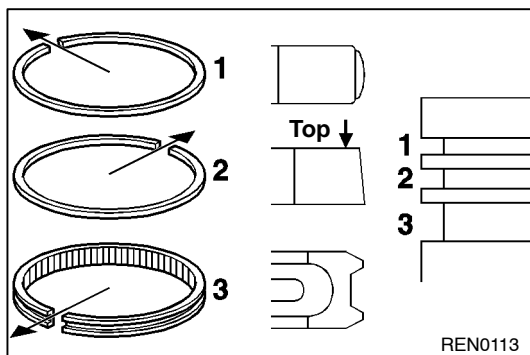

INSTALLATION SERVICE POINTS

▶A◀ PISTON RING INSTALLATION

- (1) Fit the oil ring **6**.
 - (2) Fit the No. 2 piston ring **5**.
 - (3) Fit the No. 1 piston ring **4**.
- Lubricate the piston rings with engine oil.
Position the piston ring gaps at an angle of 120° to each other.

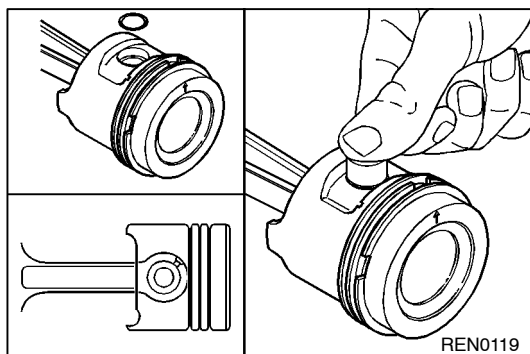

▶B◀ PISTON PIN INSTALLATION

- (1) Fit the circlip in the piston **7**.
- (2) Smear a thin layer of engine oil on the piston pin **2** before fitting. Install the connecting rod **3** with the oil passage facing away from the combustion chamber in the piston.
- (3) Insert the piston pin.
- (4) Fit the circlip in the piston **7**.

22. FLYWHEEL

REMOVAL AND INSTALLATION

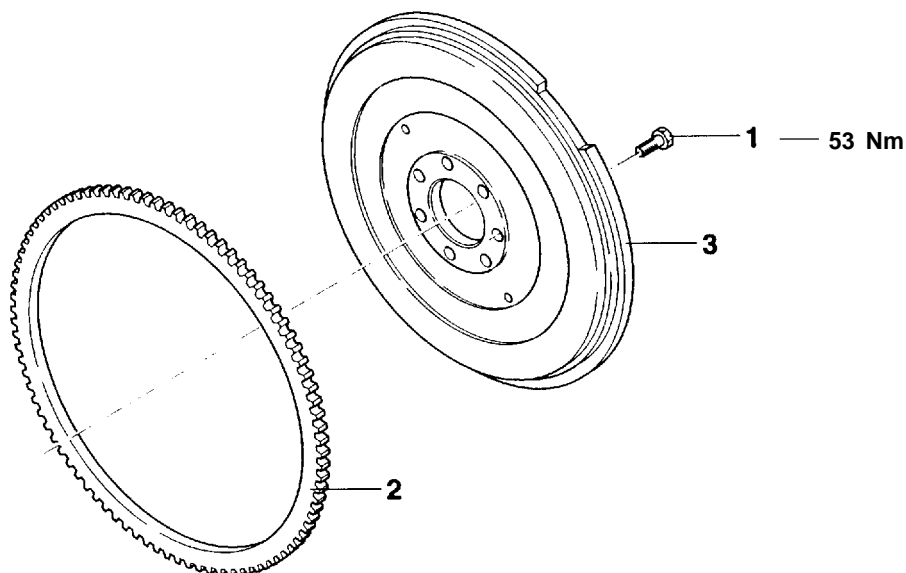

REN0120

Removal steps



1. Bolt
2. Flywheel ring gear
3. Flywheel

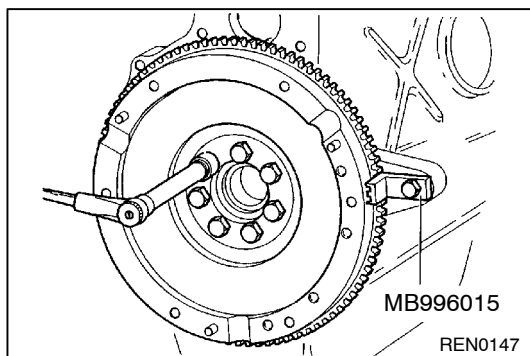

REMOVAL SERVICE POINTS

◀A▶ FLYWHEEL REMOVAL

Use flywheel stopper MB996015 to hold the flywheel during removal.

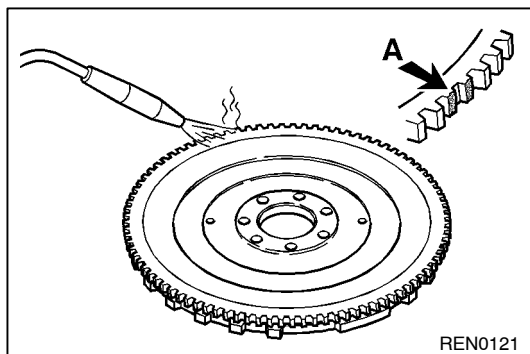

◀B▶ FLYWHEEL RING GEAR REMOVAL

- (1) Examine the flywheel ring gear **2** for damage and abnormal wear and replace if necessary.
- (2) Heat the flywheel ring gear **2** evenly with an oxyacetylene torch, or a similar device for applying heat locally, and then remove the ring gear by tapping around its entire circumference.

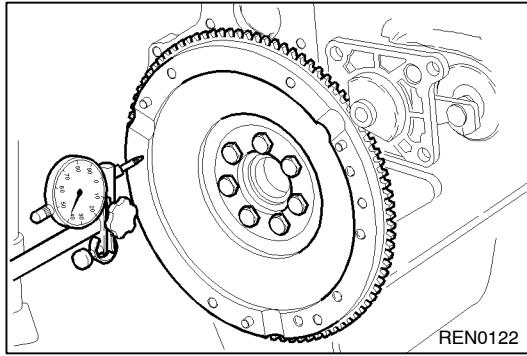

INSPECTION

FLYWHEEL

Axial throw

- (1) If the axial throw exceeds the limit value, check the flywheel for a loose bolt **1** or for a defective connection to the crankshaft. Repair or replace as necessary.

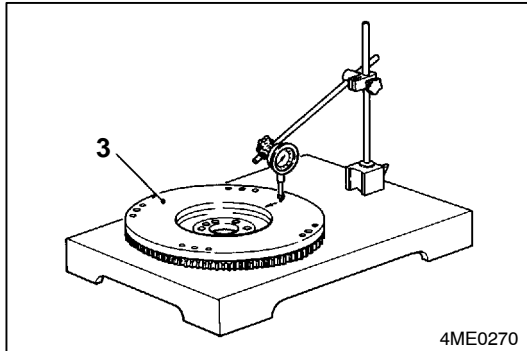

Deformation of the friction surface

- (1) If necessary, replace the flywheel **3**.

NOTE

A new flywheel is always supplied complete with the ring gear.

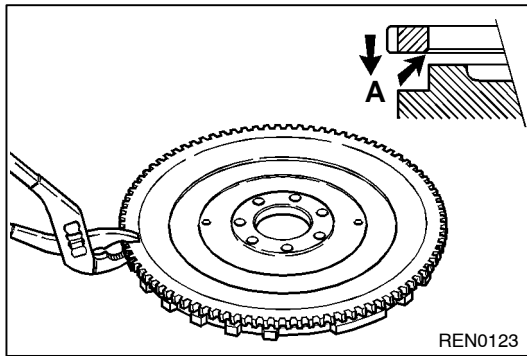

INSTALLATION SERVICE POINTS

►A◄ FLYWHEEL RING GEAR INSTALLATION

- (1) Heat the flywheel ring gear **2** with an oxyacetylene torch, or a similar device for applying heat locally, to approximately 220°C.
- (2) Fit the flywheel ring gear **2** on the flywheel **3**, with the chamfered side facing towards the flywheel.
A: Chamfered side of flywheel ring gear.

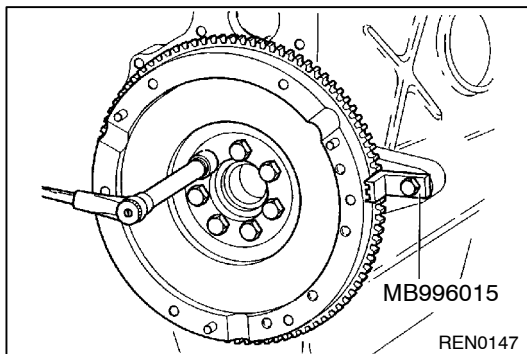

►B◄ FLYWHEEL INSTALLATION

- (1) Remove all traces of sealant, oil and other substances.

Caution

The flywheel can be fitted in one way only. This is because the bolt hole pattern is asymmetrical.

- (2) Coat the mating face of the flywheel to the crankshaft with a locking agent (Part No. 1161059-1).
- (3) Use new bolts and coat the screw threads with liquid gasket cement (Part No. 277917-1).
- (4) Use flywheel stopper MB996015 and tighten the bolts 53 Nm.

23. CRANKSHAFT AND CYLINDER BLOCK

REMOVAL AND INSTALLATION

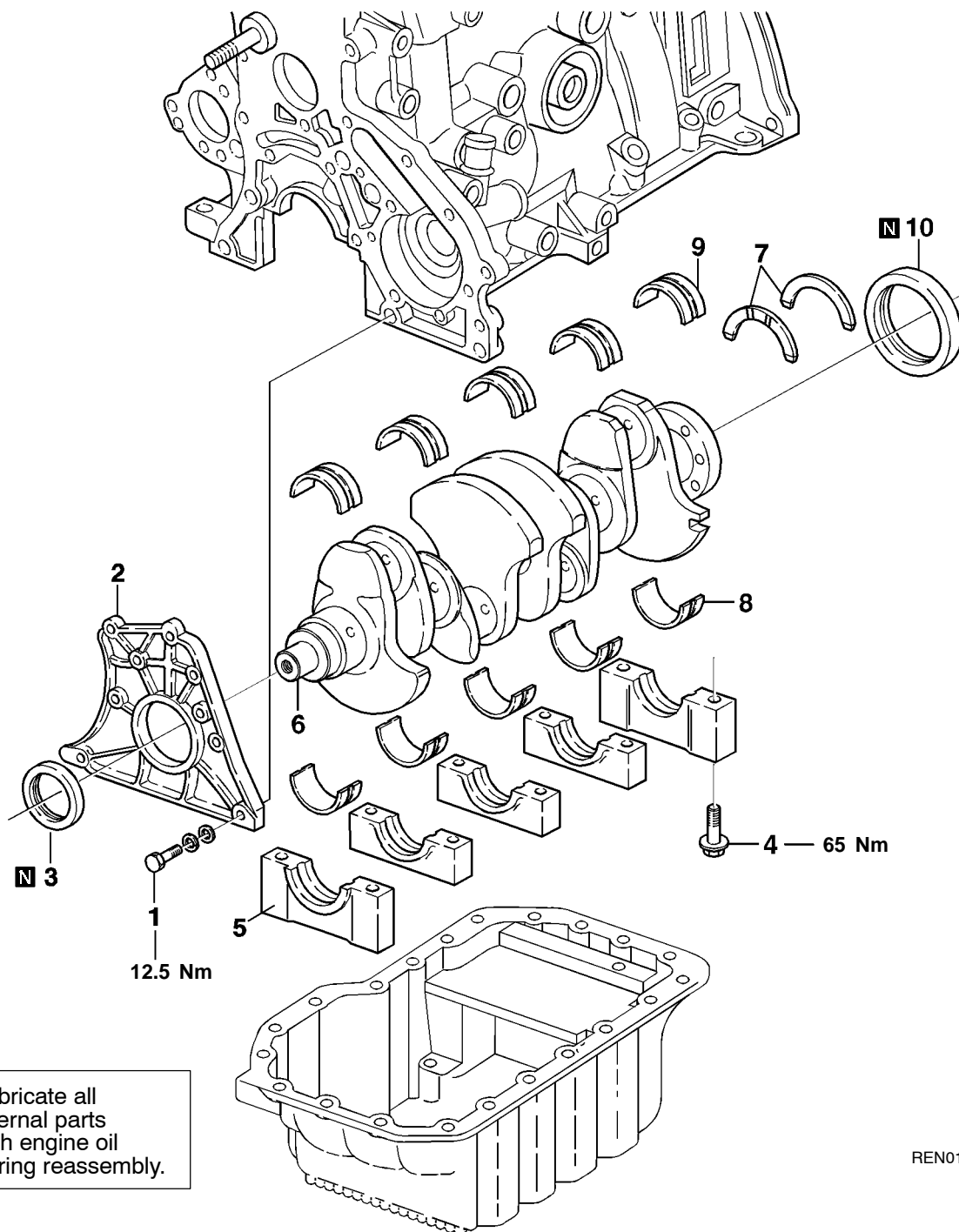

REN0124

Removal steps

- ▶C◀ 1. Bolt
- ▶D◀ 2. Front plate
- ▶D◀ 3. Oil seal
- ▶A▶▶B◀ 4. Bolt
- ▶A▶▶B◀ 5. Main bearing cap
- ▶A▶▶B◀ 6. Crankshaft
- ▶A▶▶B◀ 7. Thrust bearing
- ▶B▶▶B◀ 8. Crankshaft main bearing, lower
- ▶B▶▶B◀ 9. Crankshaft main bearing, upper
- ▶E▶▶E◀ 10. Oil seal

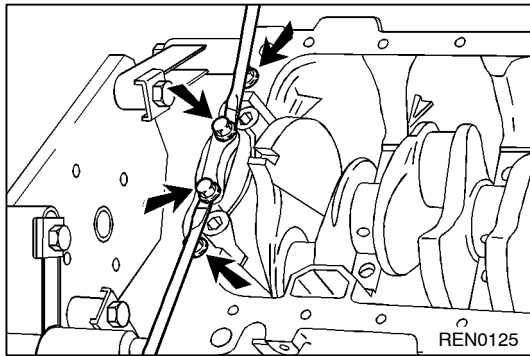

REMOVAL SERVICE POINTS

◀▶ MAIN BEARING CAP REMOVAL

- (1) Remove the retaining bolts.

NOTE

To remove No. 1 bearing cap (flywheel end) with screwdrivers, two M7 bolts must be fitted in the bearing cap and two M7 bolts in the cylinder block.

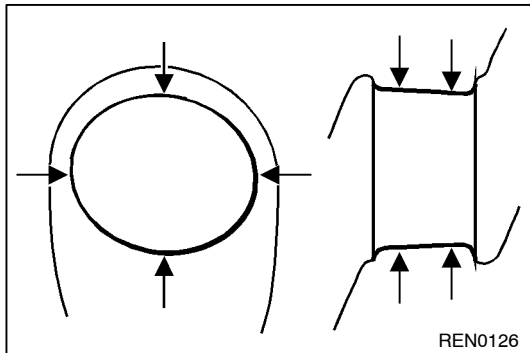

INSPECTION

CRANKSHAFT

Ovality and taper of main bearing journals and big-end bearing journals

- (1) Replace the crankshaft if the limit value is exceeded.

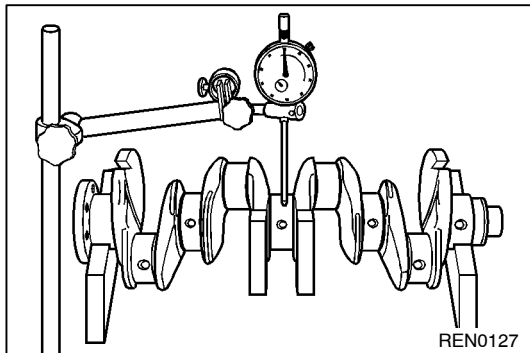

Out-of-roundness

- (1) Support the crankshaft **6** at No. 1 journal and No. 5 journal and measure the out-of-roundness at No. 3 journal. Replace the crankshaft if the limit value is exceeded.

NOTE

Turn the crankshaft through one revolution and measure the relative out-of-roundness of the main bearing journals.

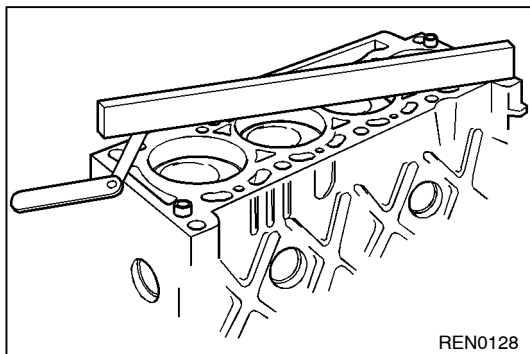

DEFORMATION OF THE CYLINDER BLOCK

- (1) Replace the cylinder block if the limit value for deformation is exceeded.

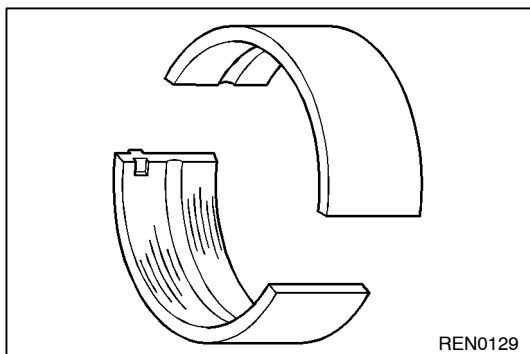

MAIN BEARINGS

Do not reuse the main bearings **8, 9** if they are badly worn or otherwise defective.

NOTE

When replacing the bearing, always replace the upper and lower bearings as a set.

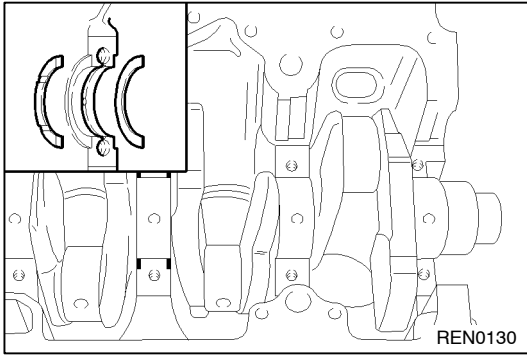

INSTALLATION SERVICE POINTS

►A◄ THRUST WASHER INSTALLATION

- (1) Fit the thrust washers 7 at No. 2 journal on the crankshaft 6.

Caution

- Fit the thrust washers 7 with the oil grooves A facing outwards.

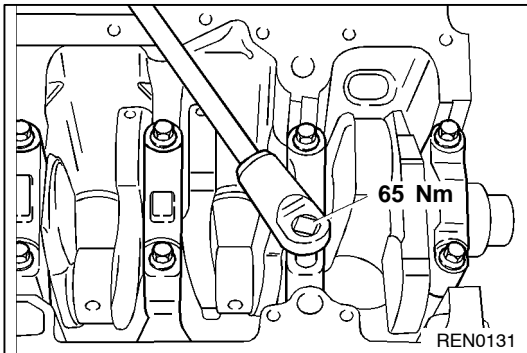

►B◄ CRANKSHAFT MAIN BEARING / MAIN BEARING CAPS INSTALLATION

Caution

- The main bearing caps are marked.
- (1) Start by installing bearing cap No. 2. The bolts should be tightened to the specified torque.
 - (2) Check that the crankshaft rotates smoothly.

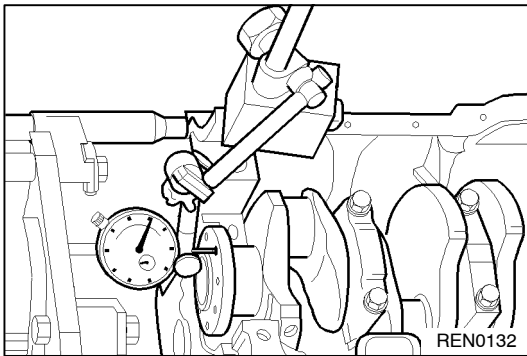

- (3) Move the crankshaft backwards and forwards in the longitudinal direction and check whether the end play is within the specified tolerance range.

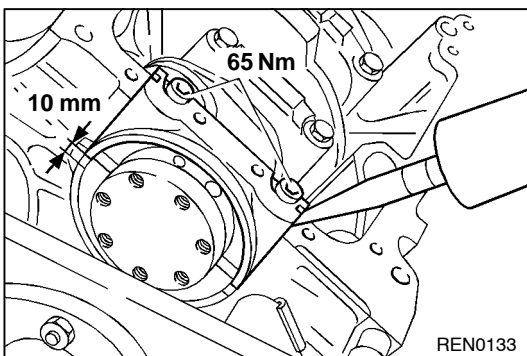

- (4) Fit the bearing cap in the cylinder block so that the mating faces are positioned about 10 mm away from each other.
- (5) Centre the bearing cap with the two socket-head screws.
- (6) Pack the two recesses in the bearing cap with sealant.

NOTE

The two recesses should be filled down to the bottom edge.

- (7) Tighten the two socket-head screws to the specified torque.
Remove excessive sealant.

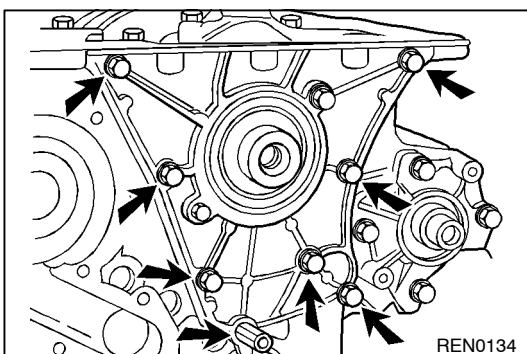

►C◄ FRONT PLATE INSTALLATION

- (1) Apply an even, uninterrupted bead of sealant to the front plate. (Maximum bead width 2 mm).

Caution

- Make sure that the surface to which the sealant is applied is free of dirt and other impurities.
- Check that the two fitted sleeves are present.

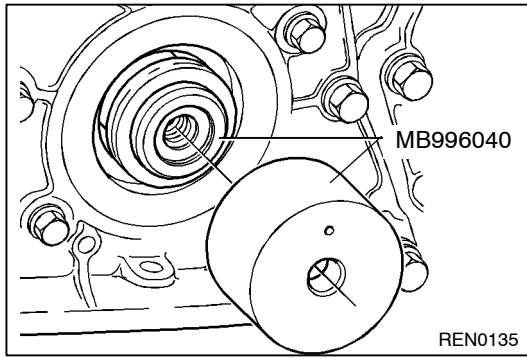
**►D◄ CRANKSHAFT FRONT OIL SEAL INSTALLATION**

- (1) Coat the lip of the oil seal with a thin layer of engine oil.
- (2) Locate the oil seal installer guide MB996040 over the crankshaft.
- (3) Locate the oil seal over the oil seal installer guide.
- (4) Fit the oil seal with oil seal installer MB996040.

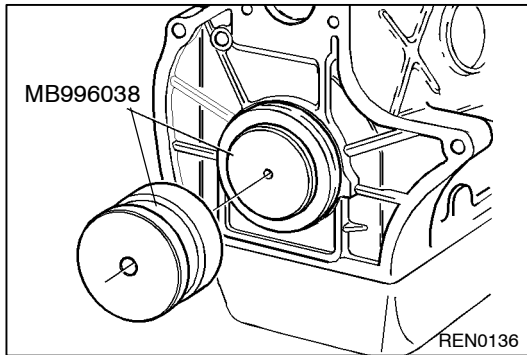
**►E◄ CRANKSHAFT REAR OIL SEAL INSTALLATION**

- (1) Coat the lip of the oil seal with a thin layer of engine oil.
- (2) Locate the installer oil seal guide MB996038 over the crankshaft.
- (3) Locate the oil seal over the oil seal installer guide.
- (4) Fit the oil seal with oil seal installer MB996038.

NOTES